



## **OPERATING INSTRUCTIONS AND REPLACEMENT PARTS**

**Models: BB15-COIS, BB30-COIS, BB50-COIS  
BB75-COIS, BB100-COIS, BB150-COIS**



### **WARNING**

This manual must be read carefully and followed by all persons who have or will have the responsibility for using or servicing this equipment. This equipment will perform as designed only if used according to the instructions. Otherwise it could fail to perform as designed, causing personal injury or death.

### **AIR SYSTEMS INTERNATIONAL, INC.**

829 Juniper Crescent, Chesapeake, Va, 23320

Telephone (757) 424-3967

Toll Free 1-800-866-8100

Fax No. (757) 424-5348

[www.airsystems.com](http://www.airsystems.com).

e-mail: [sales@airsystems.com](mailto:sales@airsystems.com)

## Specifications

	BB15 Series	BB30 Series	BB50 Series	BB75 Series	BB100 series	BB150 series
Size	19"L X 13"H X 7"D	19"L X 13"H X 7"D	24"L X 17"H X 8.5"D	24"L X 17"H X 8.5"D	26.5"L X 21"H X 9"D	26.5"L X 21"H X 9"D
Weight	18.7 lbs/8.5 kg	19.7 lbs/8.9 kg	26.4 lbs/12 kg	34.2 lbs/15.5 kg	38.8 lbs/17.6 kg	38.8 lbs/17.6 kg
Inlet Size	1/2" industrial interchange	1/2" industrial interchange	1/2" industrial interchange	1/2" industrial interchange	1/2" industrial interchange	1" Chicago
No. of Outlets	1	2 standard 3 optional	4	6 or single 1/2" NPT outlet	4-8 or single 1/2" NPT outlet	(3) 1/2" industrial interchange
Maximum Air Flow (cfm/lpm)	30 scfm @ 110 psi 850 lpm @ 7.6 bar	30 scfm @ 110 psi 850 lpm @ 7.6 bar	50 scfm @ 110 psi 1415 lpm @ 7.6 bar	75 scfm @ 110 psi 2124 lpm @ 7.6 bar	100 scfm @ 110 psi 2832 lpm @ 7.6 bar	150 scfm @ 110 psi 4248 lpm @ 7.6 bar
Remote Alarm Signal	Not Available					
Maximum Inlet Pressure	150 psi (10.3 bar)					
Relief Valve	125 psi (8.6 bar)					
Monitoring	Inline Continuous Monitoring of Carbon Monoxide (CO)					
Power	9 VDC					

## System Components

ITEM #	DESCRIPTION	BB15	BB30	BB50	BB75	BB100	BB150
1	GREEN LED	MONC005					
2	CLEAR LENS	ELDS013					
3	RED LED	MONC004					
4	AUDIBLE ALARM	ELLS004					
5	INTRINSICALLY SAFE CO MONITOR	CO-911S					
6	INLET FITTING	QDH5PL8M					QDCHI16M
7	FIRST STAGE FILTER ASSEMBLY	WL251	WL251	WL007	WL175	WL066	WL132
8	SECOND STAGE FILTER ASSEMBLY	WL253	WL253	WL008	WL177	WL017	WL059S
9	THIRD STAGE FILTER ASSEMBLY	WL257	WL257	WL009	WL179	WL018	WL060S
10	PRESSURE GAUGE	GA20160B					N/A
11	125 PSI RELIEF VALVE	VR4125BR					
12	HANSEN COUPLING	QDH3SL6M					QDH5SL12M
12A	HANSEN DUST CAP	QDH3DCAP					N/A
13	SCHRADER COUPLING	QDSSL6M					N/A
13A	SCHRADER DUST CAP	QDSDCAP					N/A
14	FLOWMETER	WL033NS					
15	PRESSURE REGULATOR	WL257	WL257	WL015	WL181	WL015	WL013A

# System Components

## MODEL BB15-COIS/BB30-COIS

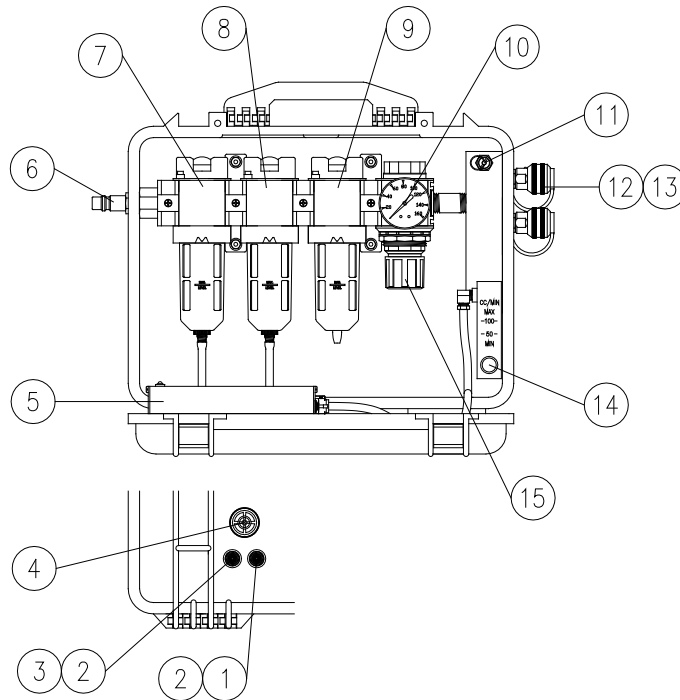

## MODELS BB50-100-COIS

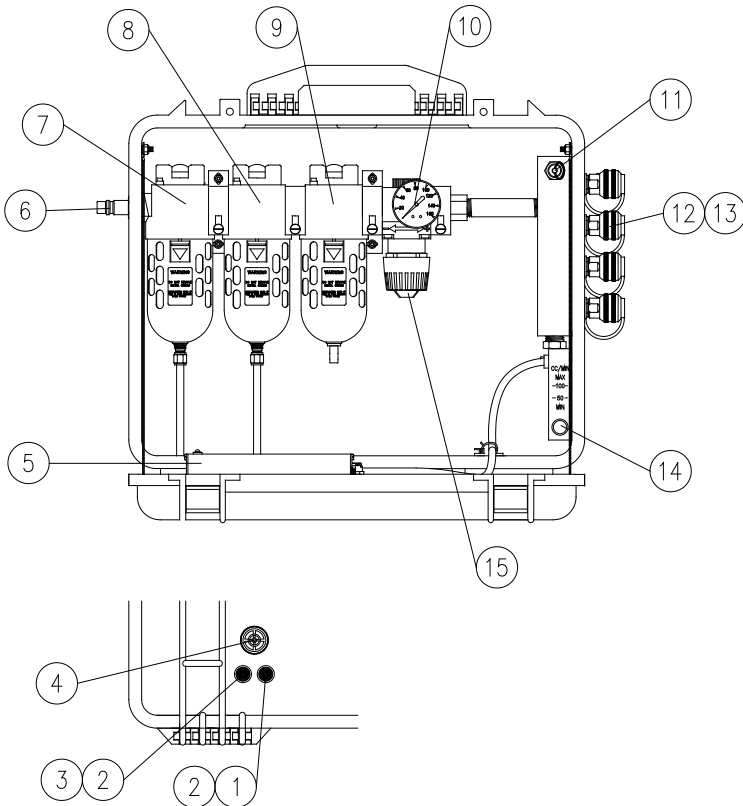

## MODEL BB150-COIS

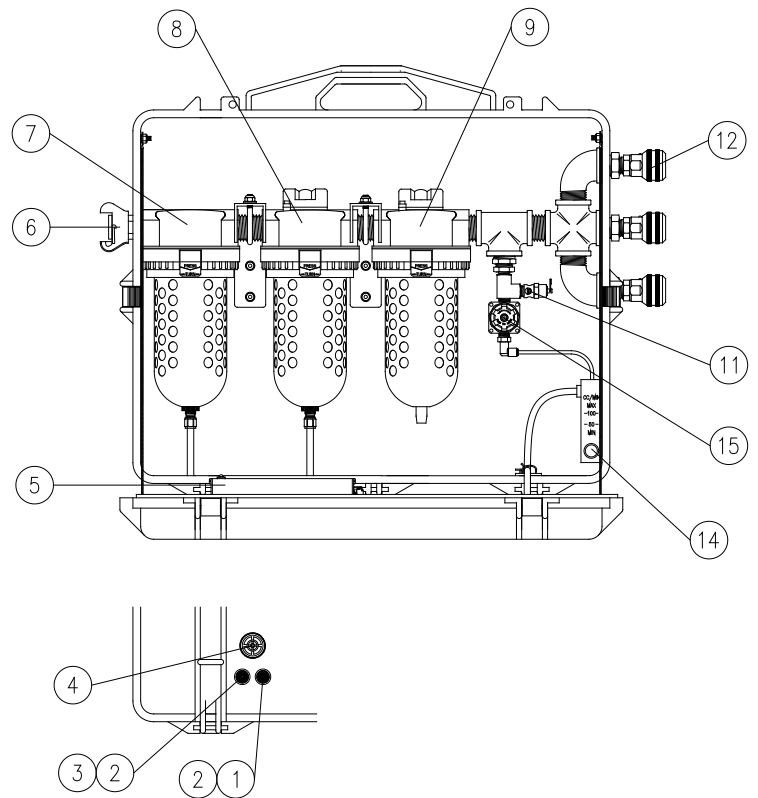

## Breathing Air Quality Position Statement

The responsibility for the quality of breathing air rests with the user. Compliance with federal, state, or local regulations are the responsibility of the user and this recommendation does not supersede any existing rules, regulations, or laws which may apply. Breathing air filtration products meet or exceed CGA Grade-D specifications for air quality as adopted by Federal OSHA. Compressor air quality standards meet or exceed OSHA 1910.134 requirements. When the components are used in accordance with the manufacturer's instructions and recommendations, the "system" meets or exceeds federal regulations presently in force. It is incumbent upon the user to comply with any changes in the regulations or law which may occur in future situations.

The air supply compressor should be located in a safe, clean ambient air environment. This "safe" location should be tested periodically using proper instruments to ensure clean ambient air quality on a consistent basis. Total system Grade-D air quality should be tested at the time of initial setup. If the compressor is moved, retesting air quality is recommended. Should the location or environment significantly change, the air quality should be retested. The compressor filters and oil level should be checked daily and changed when contaminated or when the maximum number of "run" hours is achieved.

This series of air filtration units should be used according to the recommendations specified in the manual. The standard filtration package is not explosion-proof and should be located in a non-explosive environment. (An intrinsically safe model is available, please contact the factory for information.) The carbon monoxide monitor should be calibrated monthly or if the accuracy of the monitor is in question. System air quality should be tested for, but not limited to, the following Grade-D air components:

CO - Carbon Monoxide  
 O<sub>2</sub> - Oxygen  
 CO<sub>2</sub> - Carbon Dioxide  
 H<sub>2</sub>O - Water (Moisture Content)  
 Hydrocarbons (Oil Mist)  
 Total Particulates

The maximum allowable level of these air quality components varies depending on Grade-D or E requirements. Contact sales for a copy of the latest standards.

Our Breathing Air compressors and filtration systems meet all of the following federal specifications when used and serviced in accordance with our instructions.

Federal OSHA 29 CFR 1910.134  
 "Compressor Operations for Breathing Air"

Army Corps of Engineers EM385-1-1,  
 paragraph 07b-11-4  
 "Compressed Breathing Air"

## Overview

The monitor will analyze the air sample and display the CO concentration in parts per million (ppm). The system's green "NORMAL" operation light will illuminate and the red "HIGH CO" light will flicker approximately every second when the CO level is below 10ppm (5ppm Canadian). If the CO concentration level exceeds the alarm set point, the green "NORMAL" light will turn off, the red "HIGH CO" light will illuminate, the audible alarm will sound, and the remote alarm connections will energize. Once the CO concentration levels drop below the alarm set point, all alarm indicators will deactivate and the unit will return to "NORMAL" operation.

## Monitor Specifications

Size	2.75"H X 6.57"L X 5.1"W	Sensor Type	Sealed electrochemical sensor for Carbon Monoxide
Weight	2.8 IBS. (1.27kg.)	Accuracy	+/-1% full scale
Case	Extruded Aluminum - anodized black	Response	90% in 10-15 seconds
Voltage	9 VDC	Detectable Range	0-200 ppm CO
Operating Temperature	4° to 113° Fahrenheit (-15.5° to 45° Celcius)	Calibration	Manual CO zero and span adjustments
Humidity Range	10% to 90% relative humidity	Alarm Setting	10 ppm CO (5 ppm - Canadian)
Flow Requirement	50 - 100 cc/min	Warning Signals	Normal Operation - Green Light High CO - Red Light High CO - Audible Alarm Low Battery - Amber Light
Display	3 digit LCD CO concentration	Warranty	2 years from original date of purchase
Test Circuit	Manually activated		

## Filtration Efficiency

1st Stage	Particulate/Bulk Liquid Separation	Auto drain and filter change indicator. Removes 95% bulk particulate and liquids @ 5 microns.
2nd Stage	Oil Coalescing and Ultra Fine Particulate	Auto drain and filter change indicator. Removes oil and particulate to 99.9998% @ 0.01 microns.
3rd Stage	Activated Charcoal	Manual drain and filter change indicator. Removes organic vapors, odors, and tastes. Less than 0.003 pp/wt remaining oil content.

# Carbon Monoxide Monitor System Components

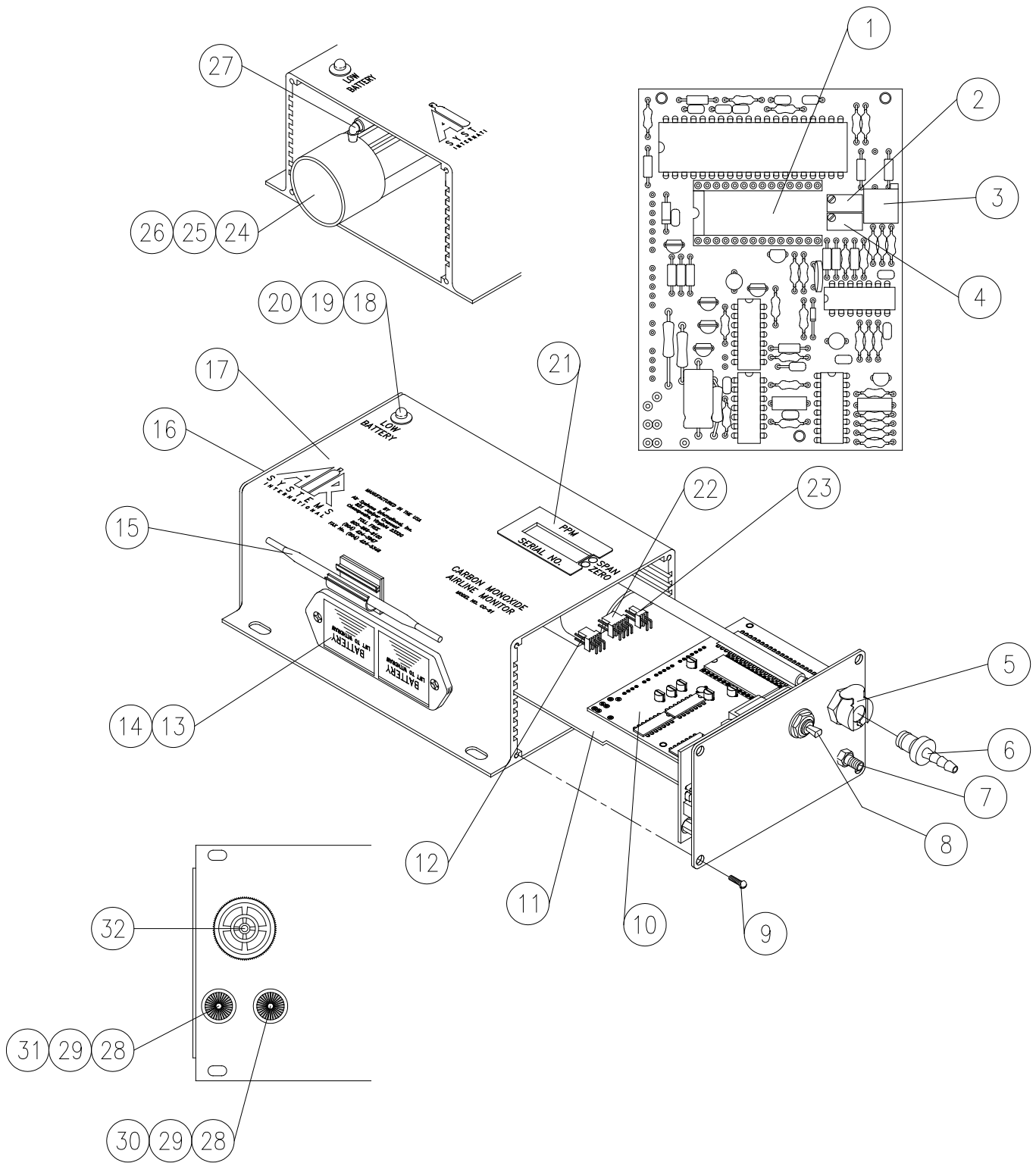

## Carbon Monoxide Monitor System Components

ITEM #	DESCRIPTION	PART #
1	LCD Display	MONC703
2	Span Potentiometer	MONC702A
3	Alarm Set Point Potentiometer	MONC702A
4	Zero Potentiometer	MONC702
5	Air Sample Inlet Socket	MONC001
6	Air Sample Plug	MONC002
7	Air Exhaust Port	MONC003
8	On/Off/Test Switch	MONC007
9	Faceplate/Endplate Screw	MONC023
10	Main Circuit Board Assembly	CO-91ISPCB
11	Power Supply Board	CO-91EXPSB
12	Sensor Connector (Soldered To PCB)	MONC509
13	Battery Box	MONC006
14	9 Volt Battery	ELB9V
15	Calibration Tool	MONC028
16	Endplate	CO-91BEP
17	Aluminum Housing	CO-91EXHOU
18	Led Socket	MONC009LA
19	Yellow LED	MONC008NS
20	LED Socket And Yellow LED	CO-91LED
21	PPM/Serial No. Sticker	MONC031
22	Battery Box Connector (Soldered To PCB)	MONC516
23	LED Connector (Soldered To PCB)	MONC511
24	CO Sensor	CO-91NS
25	CO Sensor Holder	MONC810
26	CO Sensor Electrical Leads	CO-91SL
27	90° Hose Barb	MONC811
28	Lamp Base	ELDS004
29	Green Led	MONC005
30	Clear Lens	ELDS013
31	Red Led	MONC004
32	Audible Alarm	ELLS004IS

# Breather Box® Setup And Operation

**Note: Always operate the Breather Box® in the upright position. Failure to comply may result in one or all of the following:**

- 1) Auto drains will not function properly. This may result in the contamination of the CO monitor and cause oil/water to be passed through the respirator hose and into the worker's mask.
- 2) Auto drains may become clogged.
- 3) Filters may accumulate moisture and/or contamination.

## STEP 1)

Secure a primary air source of sufficient air flow and discharge pressure. The number and type of respirators being used determines the flow rate and pressure required.

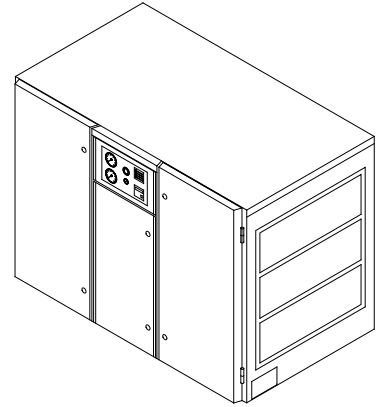

## STEP 2)

Check airline monitor for fresh 9 volt batteries and turn unit on. Connect the air sample hose to the monitor. Place the "ON/OFF/TEST" switch to the "ON" position. Allow 30 seconds for the readout to stabilize. If a reading other than "00" is displayed, calibration of the monitor may be necessary. See calibration procedure.

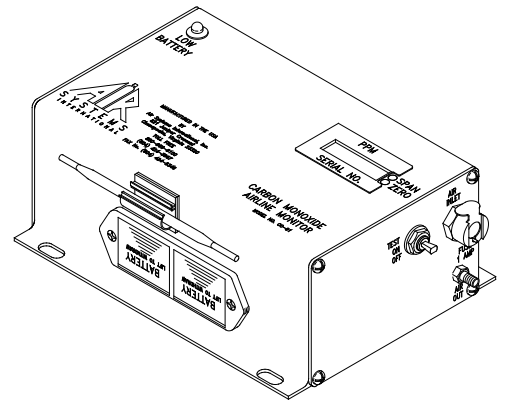

## STEP 3)

Close the flowmeter by turning the control knob fully clockwise. Do not over-tighten.

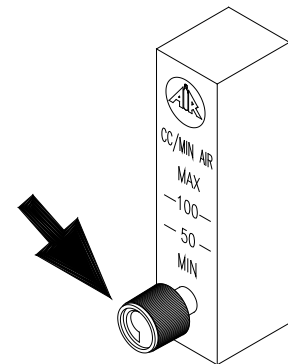

## STEP 4)

Connect the air source, 150 psi max., to the inlet fitting.

MODEL #	MIN. HOSE I.D.	INLET FITTING
BB15 SERIES	3/8"	1/2" INDUSTRIAL INTERCHANGE
BB30-100 SERIES	1/2"	1/2" INDUSTRIAL INTERCHANGE
BB150 SERIES	3/4"	1" CHICAGO FITTING

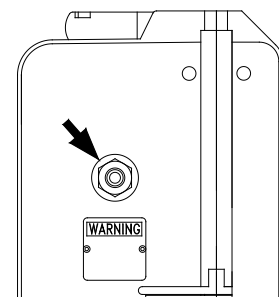



# Breather Box® Setup And Operation

## STEP 5)

Hold the “ON/OFF/TEST” switch in the “TEST” position. In the “TEST” mode the red light will be solid, the green light will blink, and the audible alarm will sound. If not, remove left endplate and check sensor connections.

**Note: An alarm function test can be performed at any time by lifting the “ON/OFF/TEST” switch to the “TEST” position.**

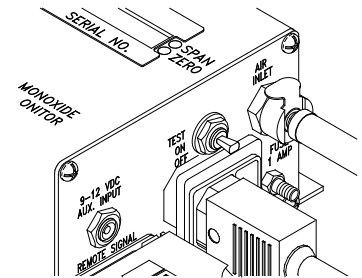

## STEP 6)

Attach desired respirators and hoses to the quick connect couplings.

**Note: Some models may not have respirator connections. They may be ordered with NPT outlets for connection to points-of-attachment.**

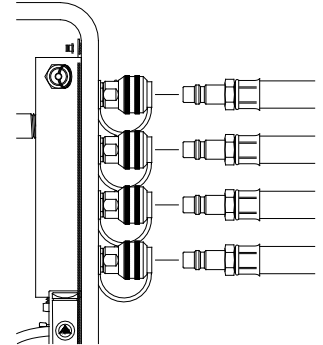

## STEP 7)

Adjust the outlet pressure to the setting recommended by the respirator manufacturer. Turn the knob clockwise to increase pressure, counterclockwise to decrease pressure.

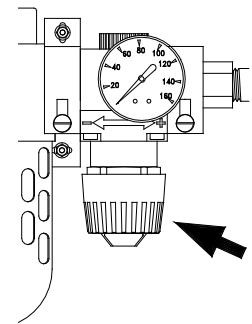

## STEP 8)

Adjust CO monitor air sample flow rate by turning the flowmeter control knob counterclockwise until the ball hovers between 50 and 100 cc/min. The box is now ready for operation.

The monitor will analyze the air sample and display the CO concentration in parts per million (ppm). The system’s green “NORMAL” operation light will illuminate, and the red “HIGH CO” light will flicker faintly approximately every second when the CO level is below 10ppm (5ppm Canadian).

When the CO concentration level exceeds the alarm set point, the green “NORMAL” light will turn off, the red “HIGH CO” light illuminates, the audible alarm will sound, and the remote alarm connections will energize.

When CO concentrations drop below the alarm set point, all alarm indicators will deactivate and return to normal operation.

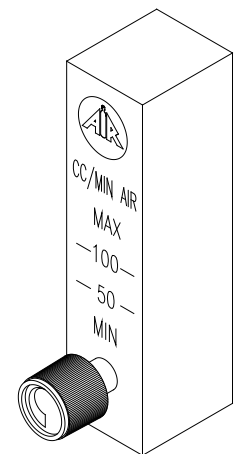

## Shutdown Procedure

- 1) Make sure all personnel have egressed from the work area.
- 2) Shut off air source to the box.
- 3) Remove air pressure from the box by pulling the relief valve ring out.
- 4) Turn the CO monitor OFF. Do not remove the 9 volt batteries. These are used to maintain a bias voltage to the sensor. This keeps the sensor ready for immediate use.
- 5) Disconnect airline hoses.
- 6) Install dust caps if applicable.

## System Maintenance

**CAUTION:** Always depressurize the system before performing service.

**Filter Housing/Bowls:** Periodic cleaning of the polycarbonate bowls may become necessary. Remove the auto drains and clean the bowls with a mild soapy solution. The auto drains may also be cleaned with a mild soapy solution at this time. Dry and reinstall into the filter housing.

**Filter Change:** The filtration system consists of filter change indicators which will gradually change from green to orange when filter life is spent.

**Note:** Air must be flowing through the filters before the filter change indicators will function.

**Calibration:** Monitor calibration should be done monthly or whenever the reading may be questionable. A calibration date sticker should be affixed for future reference. To obtain an accurate calibration, we recommend the use of Air Systems' calibration kits.

**Part Number:**

BBK-10 Canadian calibration kit for CO monitor; 10ppm CO, zero air, regulator and case - 17 liter size.

BBK-20 Calibration kit for CO monitor; 20ppm CO, zero air, regulator and case - 17 liter size.

BBK-20103 Calibration kit for CO monitor; 20ppm CO, zero air, regulator and case - 103 liter size.

DECAL085CD Calibration decal card, contains 14 calibration decals.

To assure sensor accuracy, calibration of monitor is required. If you cannot obtain an accurate calibration, sensor replacement may be necessary. Consult Repair Service Department before ordering.

**Part Number:**

CO-91NS Replacement CO sensor

## Monitor Battery Replacement

These batteries provide the required continuous bias voltage to the CO sensor and power the monitor in the event of AC power loss. If AC and DC power are removed for a period of 2 hours or more, a 1 hour restabilization period is required as erratic readings may occur.

**Battery Replacement:** Replace 9 volt batteries when the amber "Low Battery" light illuminates. If the monitor is not used for 90 days, check the 9 volt batteries and replace if necessary.

## Sensor Replacement

Replacement sensors are shipped with a metal spring installed between the electrodes. Do not remove the clip until the sensor is to be installed into the monitor.

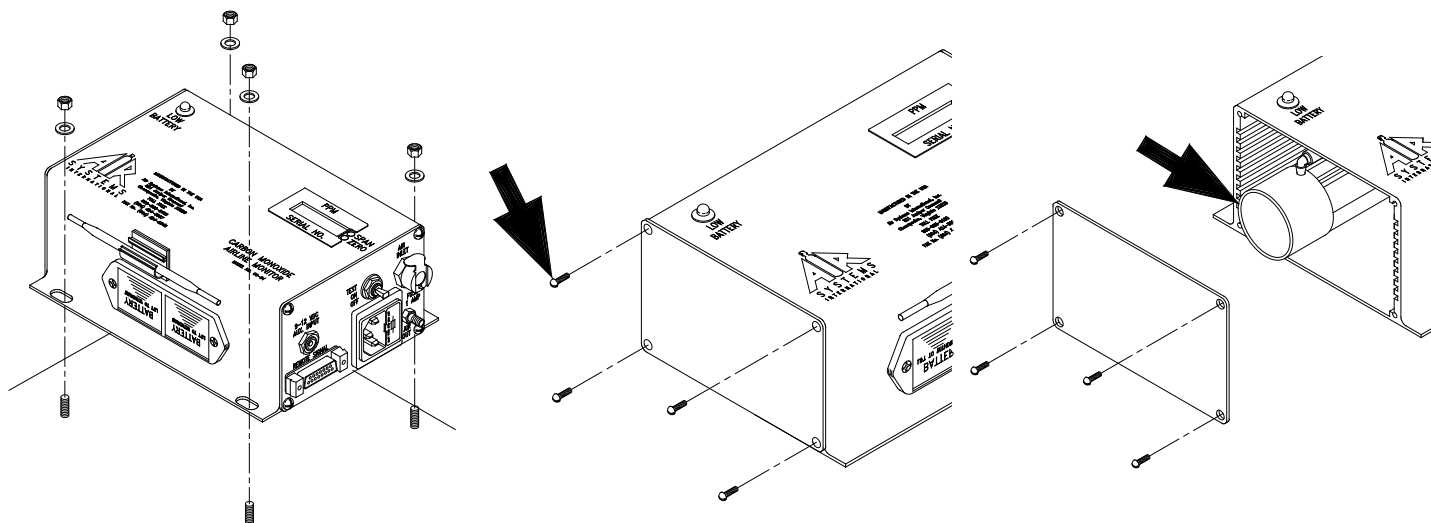

### Step 1)

Disconnect all external connections. Remove CO monitor from the unit.

### Step 2)

Remove the four screws from the monitor's left endplate.

### Step 3)

Remove endplate to gain access to the sensor cup.

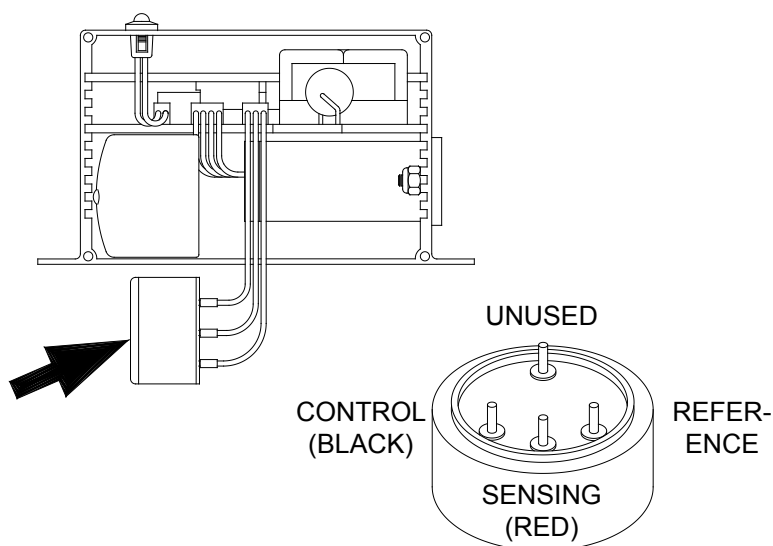

### Step 4)

Remove sensor from sensor cup and remove leads. Take the new sensor and remove the metal spring. Reattach leads to the proper colored terminals on the new sensor. Install new sensor into sensor cup.

### Step 5)

Reassemble monitor and reinstall in unit. Connect all cables and air sample hose. Allow monitor to stabilize 30 minutes to 1 hour and recalibrate.

# Calibration Procedure

**Do not use inert gases to zero the monitor. This will cause premature failure of the sensor.**

## CO Monitor Zero Adjustment

To zero the monitor, follow the steps below. Zero calibration gas should be used to properly “zero” the monitor and assure that a valid calibration is achieved. If zero adjustment cannot be made as indicated, sensor replacement may be necessary. **After each monitor adjustment outlined in the steps, allow time for the changes to stabilize.**

### STEP 1)

Place the “ON/OFF/TEST” switch in the “ON” position.

### STEP 2)

Allow 30 seconds for the readout to stabilize. The green indicator will illuminate.

### STEP 3)

Hold the “ON/OFF/TEST” switch in the “TEST” position. The following will occur:

- Audible alarm will sound
- Green LED will flash
- Amber Low Battery indicator on monitor will illuminate
- Red LED will be on

This test ensures the circuitry is operable and continuity to the sensor is proper. Release the switch.

### STEP 4)

Remove the air sample inlet tube.

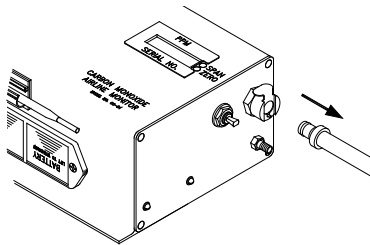

### STEP 5)

Install regulator on the zero air cylinder reference gas.

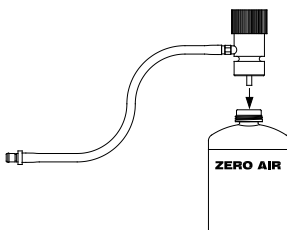

### STEP 6)

Turn the knob on the regulator counterclockwise to allow the flow of gas thru the hose. Verify flow of gas thru the hose via touch or sound.

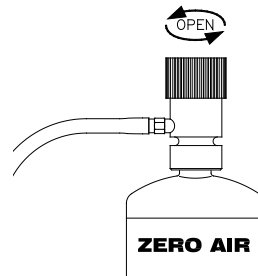

### STEP 7)

Attach the clear tubing with the male plug to the air sample inlet on the monitor.

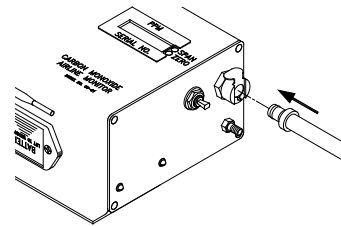

### STEP 8)

Allow digital readout to stabilize approximately 15-30 seconds.

### STEP 9)

Adjust the “zero” adjustment screw (clockwise to increase or counterclockwise to decrease) until a reading of “00” is obtained.

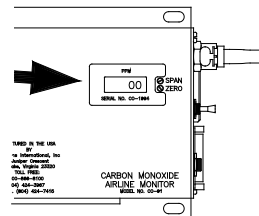

### STEP 10)

Turn the regulator off and disconnect the regulator from the zero air cylinder.

# Calibration Procedure

## CO Monitor Span Adjustment

Use only 10-20ppm CO gas for calibration. Using a higher concentration may decrease accuracy at lower scale readings.  
 Note: 10ppm gas must be used to satisfy Canadian calibration requirements.

### STEP 1)

Install regulator on the CO calibration gas cylinder.

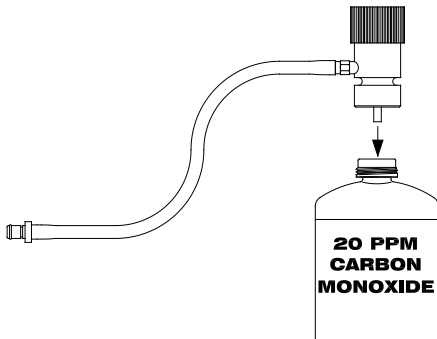

### STEP 2)

Turn the knob on the regulator counterclockwise to allow the flow of gas thru the hose. Verify flow of gas thru the hose via touch or sound.

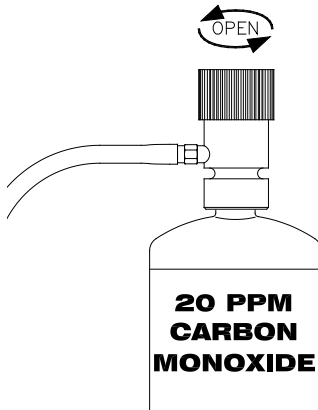

### STEP 3)

Connect the plug to the air sample inlet on the monitor.

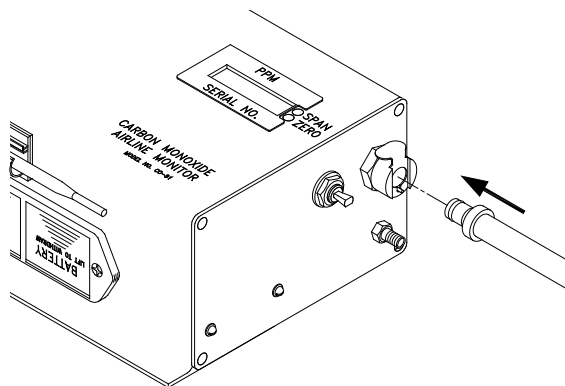

### STEP 4)

Allow digital readout to stabilize 15-30 seconds.

### STEP 5)

Adjust the "span" adjustment screw (clockwise to increase or counterclockwise to decrease) until the digital readout reads the same as the concentration (ppm) as printed on the calibration gas cylinder.

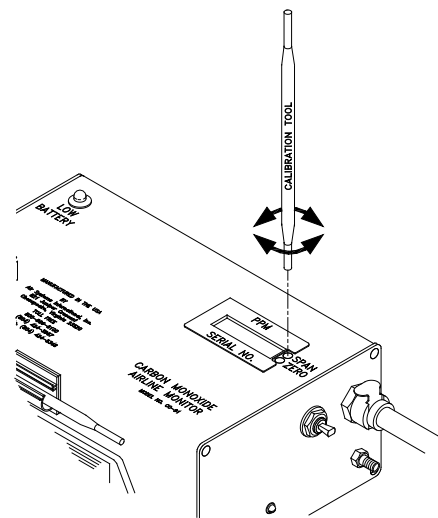

### STEP 6)

Turn the regulator off and repeat the "zero" adjustment procedure. The digital readout should return to a "00" reading.

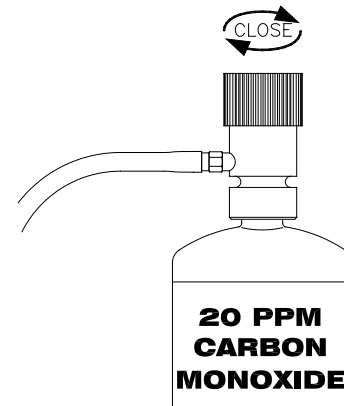

***The monitor is now calibrated and should be recalibrated monthly or if accuracy is questionable. Check local requirements and recalibrate as required.***

## Models BB15-COIS and BB30-COIS Filter Breakdown

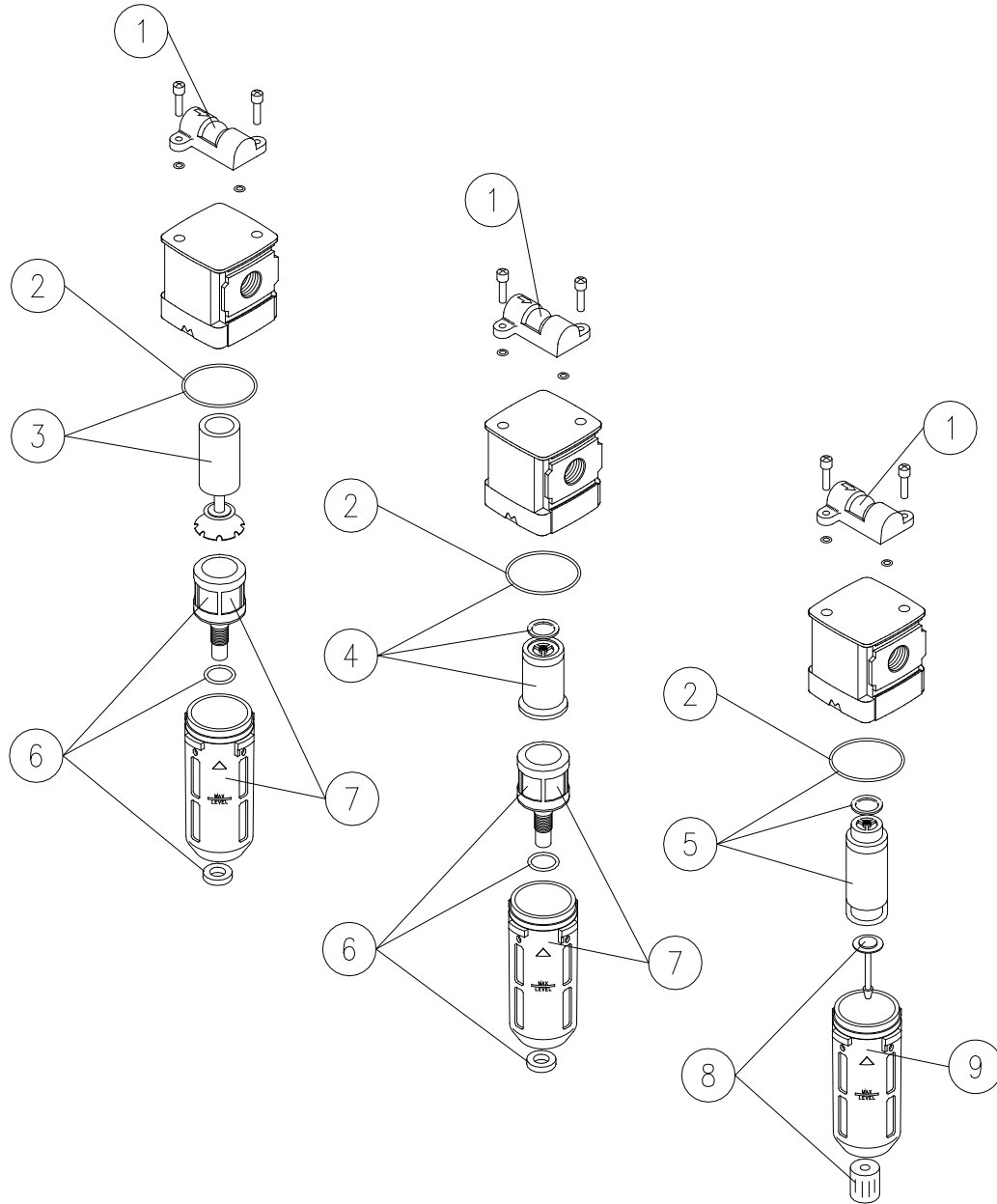

ITEM #	DESCRIPTION	PART #
1	FILTER CHANGE INDICATOR	WL261
2	FILTER BOWL O-RING	WL266
3	"A" FILTER ELEMENT AND O-RING	BB30-A
4	"C" FILTER ELEMENT AND O-RINGS	BB30-C
5	"D" FILTER ELEMENT AND O-RINGS	BB30-D
6	AUTO DRAIN ASSEMBLY	WL024
7	FILTER BOWL WITH GUARD AND AUTO DRAIN	WL264
8	MANUAL DRAIN	WL262
9	FILTER BOWL WITH GUARD (NO DRAIN)	WL267

**NOTE: For BB15 series units purchased prior to 06/14, please contact customer service for correct ordering information on replacement filter components.**

## Models BB50-COIS Filter Breakdown

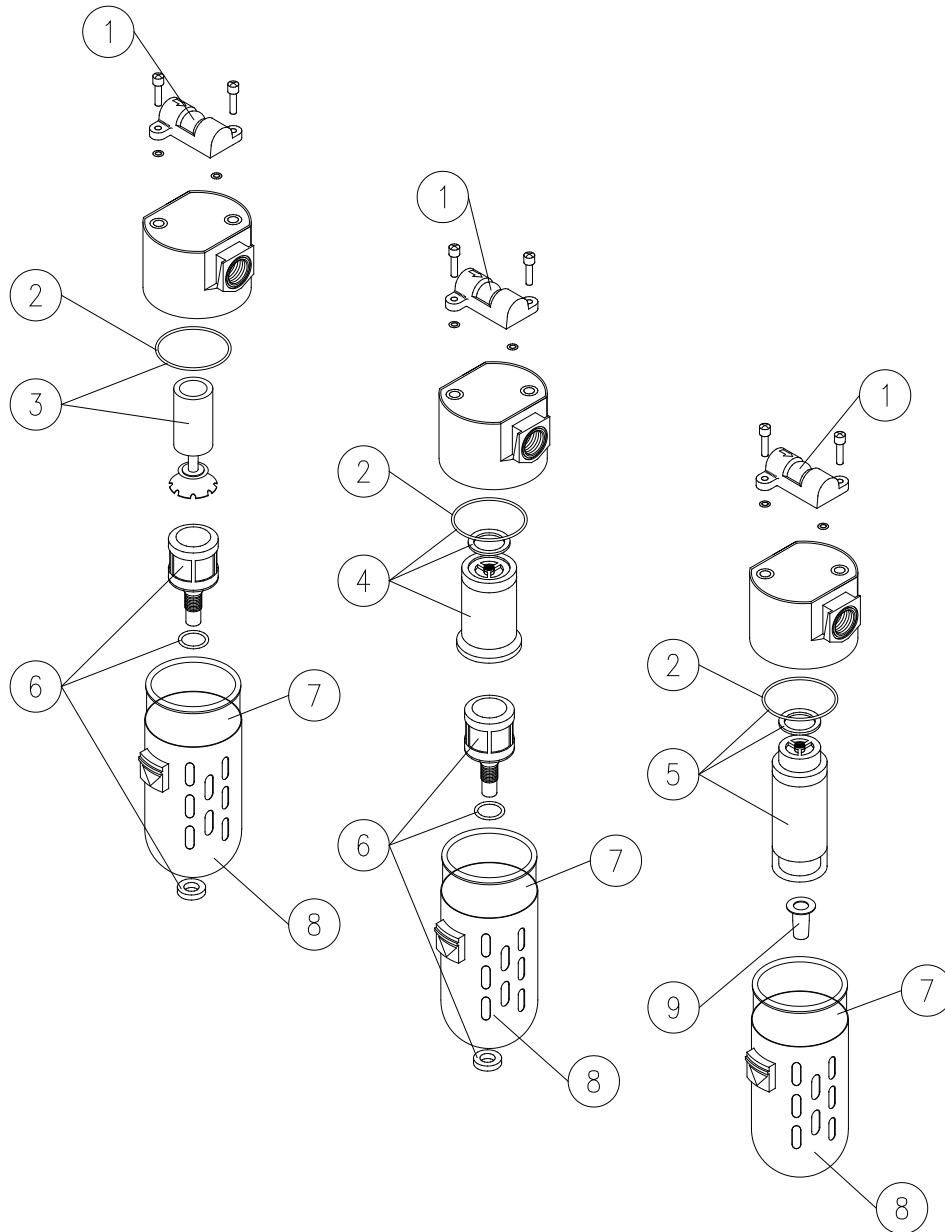

ITEM #	DESCRIPTION	PART #
1	FILTER CHANGE INDICATOR	WL056
2	FILTER BOWL O-RING	WL091
3	"A" FILTER ELEMENT AND O-RING	BB50-A
4	"C" FILTER ELEMENT AND O-RINGS	BB50-C
5	"D" FILTER ELEMENT AND O-RINGS	BB50-D
6	AUTO DRAIN ASSEMBLY	WL024
7	PLASTIC FILTER BOWL	WL049
8	METAL FILTER BOWL GUARD	WL094
9	MANUAL DRAIN	WL153

## Models BB75-COIS Filter Breakdown

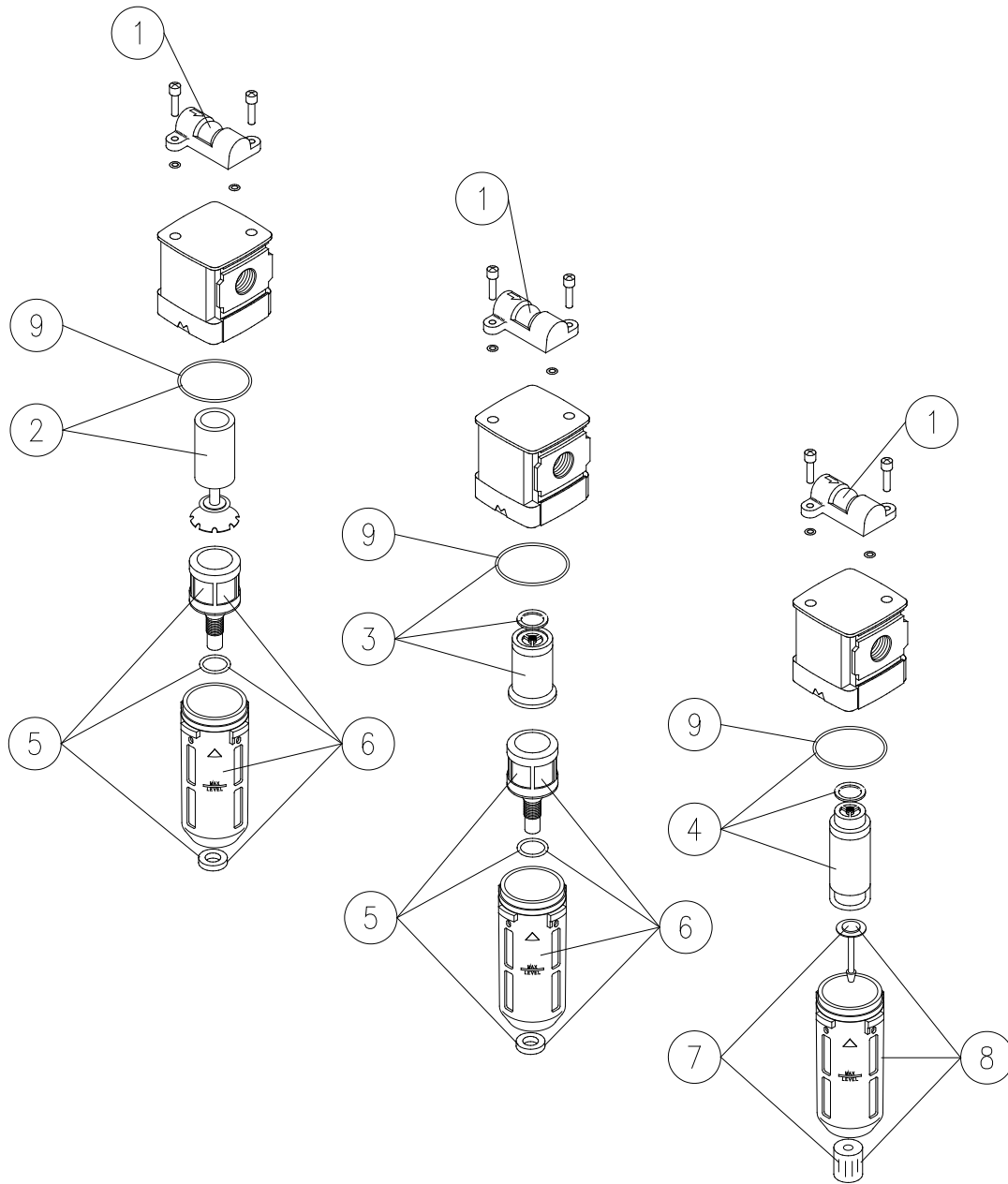

ITEM #	DESCRIPTION	PART #
1	FILTER CHANGE INDICATOR	WL261
2	"A" FILTER ELEMENT AND O-RING	BB75-A
3	"C" FILTER ELEMENT AND O-RINGS	BB75-C
4	"D" FILTER ELEMENT AND O-RINGS	BB75-D
5	AUTO DRAIN ASSEMBLY	WL024
6	FILTER BOWL WITH AUTO DRAIN	WL187
7	MANUAL DRAIN	WL262
8	FILTER BOWL WITH MANUAL DRAIN	WL188
9	FILTER BOWL O-RING	WL189



## Models BB100-COIS and BB150-COIS Filter Breakdown

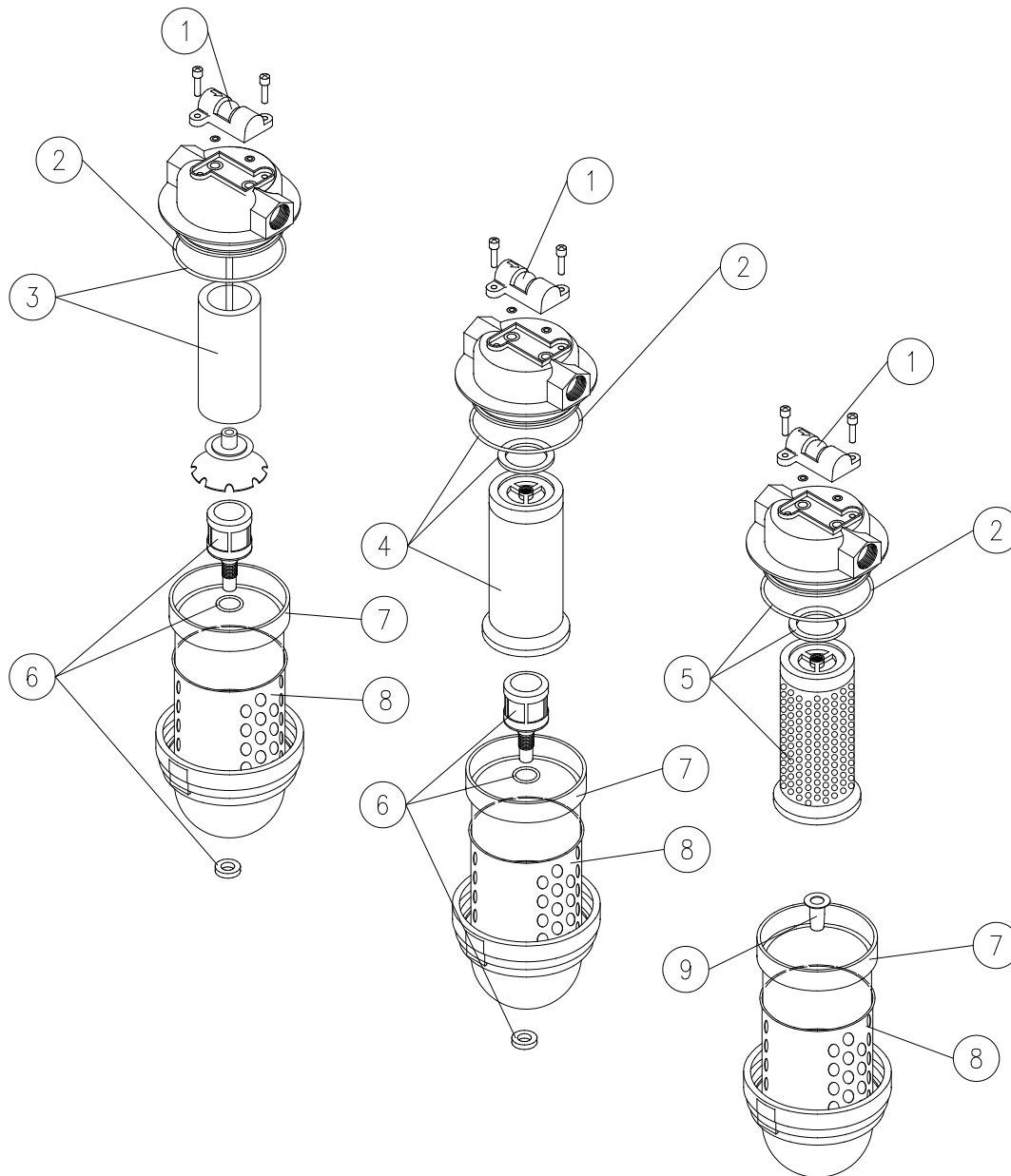

ITEM #	DESCRIPTION	PART #
1	FILTER CHANGE INDICATOR*	WL056
2	FILTER BOWL O-RING	WL113
3	"A" FILTER ELEMENT AND O-RING	BB100-A
4	"C" FILTER ELEMENT AND O-RINGS	BB100-C
5	"D" FILTER ELEMENT AND O-RINGS	BB100-D
6	AUTO DRAIN ASSEMBLY	WL024
7	PLASTIC FILTER BOWL	WL055
8	METAL FILTER BOWL GUARD	WL092
9	MANUAL DRAIN	WL153

**NOTE: On MODEL BB100-CO filters (shown above) filter change indicators are on all three filters. On MODEL BB150-CO only the "C" filter has a filter change indicator.**



## Warranty

Air Systems' manufactured equipment is warranted to the original user against defects in workmanship or materials under normal use for one year from the date of purchase. Any part which is determined by Air Systems to be defective in material or workmanship will be, as the exclusive remedy, repaired or replaced at Air Systems' option. This warranty does not apply to electrical systems or electronic components. Electrical parts are warranted, to the original user, for 90 days from the date of sale. During the warranty period, electrical components will be repaired or replaced at Air Systems' option.

**NO OTHER WARRANTY, EXPRESSED OR IMPLIED, AS TO DESCRIPTION, QUALITY, MERCHANTABILITY, FITNESS FOR A PARTICULAR PURPOSE, OR ANY OTHER MATTER IS GIVEN BY AIR SYSTEMS IN CONNECTION HERewith. UNDER NO CIRCUMSTANCES SHALL THE SELLER BE LIABLE FOR LOSS OF PROFITS, ANY OTHER DIRECT OR INDIRECT COSTS, EXPENSES, LOSSES, OR DAMAGES ARISING OUT OF DEFECTS IN, OR FAILURE OF THE PRODUCT OR ANY PART THEREOF.**

The purchaser shall be solely responsible for compliance with all applicable Federal, State and Local OSHA and/or MSHA requirements. Although Air Systems International believes that its products, if operated and maintained as shipped from the factory and in accordance with our "operations manual", conform to OSHA and/or MSHA requirements, there are no implied or expressed warranties of such compliance extending beyond the limited warranty described herein. Product designs and specifications are subject to change without notice. Rev. 2, 12/98

Air leaks are not covered under warranty except when they result from a defective system component, i.e. an on/off valve or regulator or upon initial delivery due to poor workmanship. Air leaks due to poor delivery or damage will be covered under delivery claims. Minor air leaks are part of routine service and maintenance and are the responsibility of the customer just as are filters and oil changes.

