



OPERATING MANUAL

MODELS:

BB15-CO

BB75-CO

BB30-CO

BB100-CO

BB50-CO

BB150-CO



AIR SYSTEMS INTERNATIONAL, INC.

829 Juniper Crescent, Chesapeake, Va 23320

Telephone (757) 424-3967

Toll Free 1-800-866-8100

Fax No. (757) 424-5348

<http://www.airsystems.com>

e-mail: sales@airsystems.com

BREATHER BOX™ PARTS IDENTIFICATION

MODEL BB15-CO

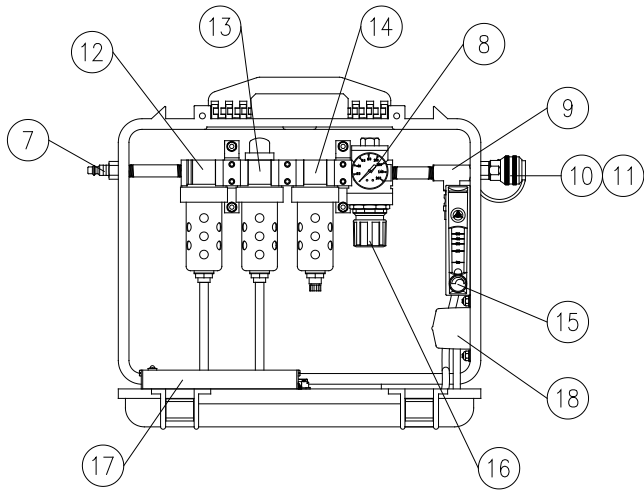

MODEL BB30-CO

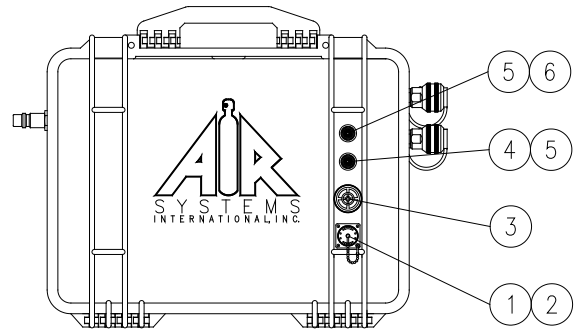
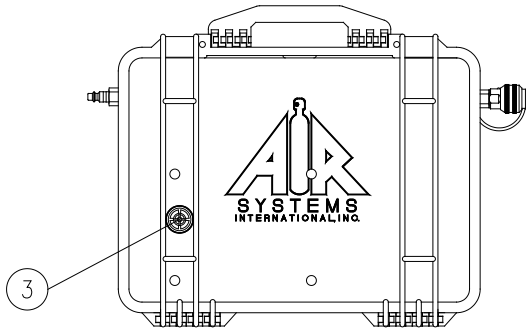
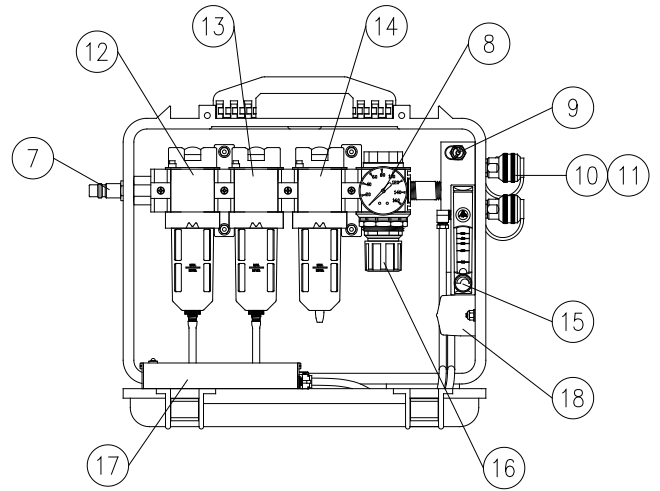

MODELS BB50-100-CO

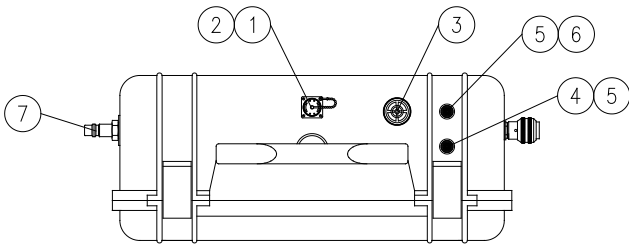

MODEL BB150-CO

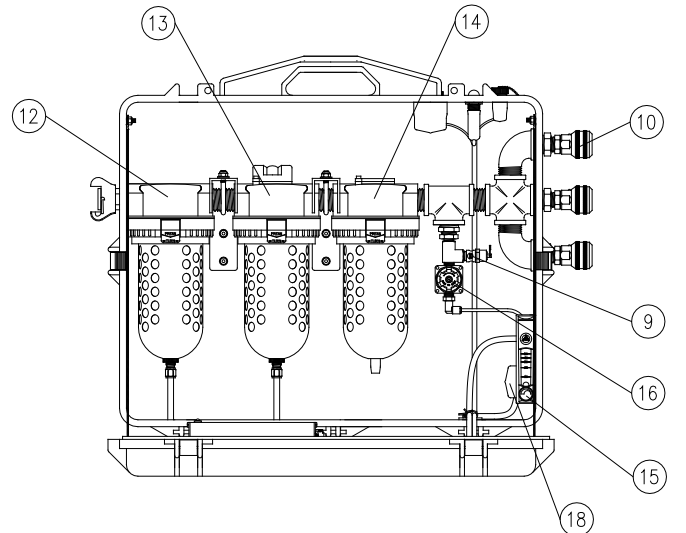
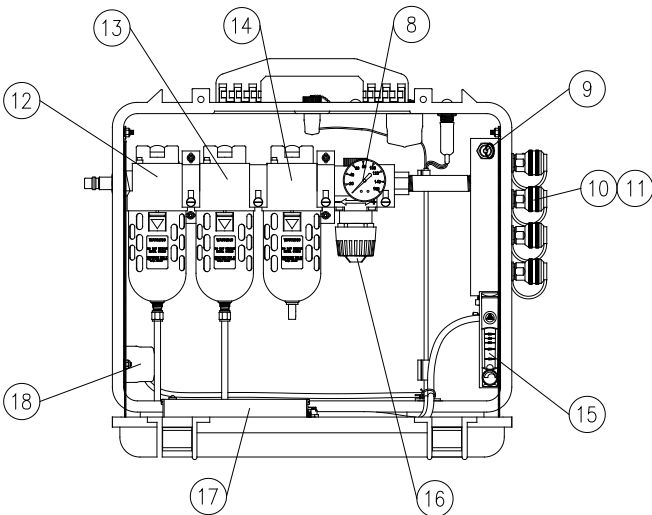
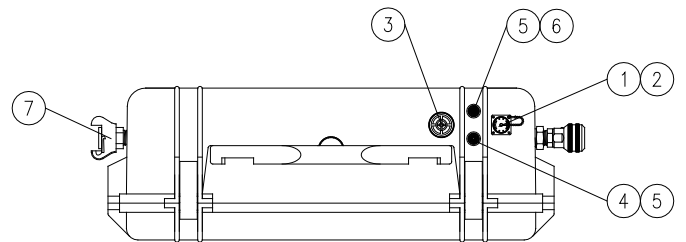

Breathing Air Quality Position Statement

The responsibility for the quality of breathing air rests with the user. Compliance with federal, state, or local regulations are the responsibility of the user and this recommendation does not supersede any existing rules, regulations, or laws which may apply. Breathing air filtration products meet or exceed CGA Grade-D specifications for air quality as adopted by Federal OSHA. Compressor air quality standards meet or exceed OSHA 1910.134 requirements. When the components are used in accordance with the manufacturer's instructions and recommendations, the "system" meets or exceeds federal regulations presently in force. It is incumbent upon the user to comply with any changes in the regulations or law which may occur in future situations.

The air supply compressor should be located in a safe, clean ambient air environment. This "safe" location should be tested periodically using proper instruments to ensure clean ambient air quality on a consistent basis. Total system Grade-D air quality should be tested at the time of initial setup. If the compressor is moved, retesting air quality is recommended. Should the location or environment significantly change, the air quality should be retested. The compressor filters and oil level should be checked daily and changed when contaminated or when the maximum number of "run" hours is achieved.

This series of air filtration units should be used according to the recommendations specified in the manual. The standard filtration package is not explosion-proof and should be located in a non-explosive environment. (An intrinsically safe model is available, please contact the factory for information.) The carbon monoxide monitor should be calibrated monthly or if the accuracy of the monitor is in question. System air quality should be tested for, but not limited to, the following Grade-D air components:

CO - Carbon Monoxide
 O₂ - Oxygen
 CO₂ - Carbon Dioxide
 H₂O - Water (Moisture Content)
 Hydrocarbons (Oil Mist)
 Total Particulates

The maximum allowable level of these air quality components varies depending on Grade-D or E requirements. Contact sales for a copy of the latest standards.

Our Breathing Air compressors and filtration systems meet all of the following federal specifications when used and serviced in accordance with our instructions.

Federal OSHA 29 CFR 1910.134
 "Compressor Operations for Breathing Air"

Army Corps of Engineers EM385-1-1,
 paragraph 07b-11-4,
 "Compressed Breathing Air"

CARBON MONOXIDE MONITOR OVERVIEW

The monitor will analyze the air sample and display the CO concentration in parts per million (ppm). The system's green "NORMAL" operation light will illuminate and the red "HIGH CO" light will flicker approximately every second when the CO level is below 10ppm (5ppm Canadian). If the CO concentration level exceeds the alarm set point, the green "NORMAL" light will turn off, the red "HIGH CO" light will illuminate, the audible alarm will sound, and the remote alarm connections will energize. Once the CO concentration levels drop below the alarm set point, all alarm indicators will deactivate and the unit will return to "NORMAL" operation.

MONITOR SPECIFICATIONS

Size	2.75"H X 6.57"L X 5.1"W	Test Circuit	Manually activated
Weight	2.8 IBS. (1.27kg.)	Sensor Type	Sealed electrochemical sensor for Carbon Monoxide
Case	Extruded Aluminum - anodized black	Accuracy	+/-1% full scale
Voltage	115 VAC and/or 9-16 VDC	Response	90% in 10-15 seconds
Shielding	Internal RFI/EMI filters	Detectable Range	0-200 ppm CO
Fuse	115 VAC/1 amp fast acting	Calibration	Manual CO zero and span adjustments
Operating Temperature	4° to 113° Fahrenheit (-15.5° to 45° Celcius)	Alarm Setting	10 ppm CO (5 ppm - Canadian)
Humidity Range	10% to 90% relative humidity	Warning Signals	Normal operation - Green Light High CO - Red Light High CO - Audible Alarm Low Battery - Amber Light
Flow Requirement	50 - 100 cc/min	Warranty	2 years from original date of purchase
Display	3 digit LCD CO concentration		

15 PIN CONNECTOR WIRING DIAGRAM

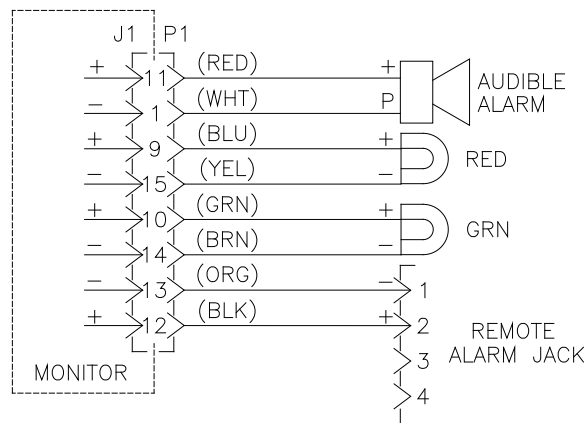

FILTRATION EFFICIENCY

1st Stage	Particulate/Bulk Liquid Separation	Auto drain and filter change indicator. Removes 95% bulk particulate and liquids @ 5 microns.
2nd stage	Oil Coalescing and Ultra Fine Particulate	Auto drain and filter change indicator. Removes oil and particulate to 99.9998% @ 0.01 microns.
3rd Stage	Activated Charcoal	Manual drain and filter change indicator. Removes organic vapors, odors, and tastes. Less than 0.003 pp/wt remaining oil content.

CO MONITOR PARTS BREAKDOWN

ITEM #	DESCRIPTION	PART #
1	LCD Display	MONC703
2	Span Potentiometer	MONC702A
3	Alarm Set Point Potentiometer	MONC702A
4	Zero Potentiometer	MONC702
5	Air Sample Inlet Socket	MONC001
6	Air Sample Plug	MONC002
7	Air Exhaust Port	MONC003
8	On/Off/Test Switch	MONC007
9	Recessed Plug With Fuse Holder	MONC020
10	1 Amp Fast Acting Fuse, 5 X 20Mm	ELF001
11	15 Pin Socket	MONC520
12	Faceplate/Endplate Screw	MONC023
13	Main Circuit Board Assembly	CO-91PCB
14	Power Supply Board	CO-91PSB
15	Sensor Connector (Soldered To PCB)	MONC509
16	Battery Box	MONC006
17	9 Volt Battery	ELB9V
18	Calibration Tool	MONC028
19	End Plate	CO-91BEP
20	Aluminum Housing	CO-91HOU
21	Led Socket	MONC009LA
22	Yellow Led	MONC008NS
23	Led Socket And Yellow Led	CO-91LED
24	PPM/Serial No. Sticker	MONC031
25	Battery Box Connector (Soldered To PCB)	MONC516
26	Led Connector (Soldered To PCB)	MONC511
27	12 VDC Power Socket	MONC522
28	12 Volt Power Plug (Optional)	ELJP018
29	12 Volt Cable (Order By The Foot)	ELCB035
30	CO Sensor	CO-91NS
31	CO Sensor Holder	MONC810
32	CO Sensor Electrical Leads	CO-91SL
33	90° Hose Barb	MONC811

BREATHER BOX™ SETUP AND OPERATION

Note: Always operate the Breather Box™ in the upright position. Failure to comply may result in one or all of the following:

- 1) Auto drains will not function properly. This may result in the contamination of the CO monitor and cause oil/water to be passed through respirator hose and into the worker's mask.
- 2) Auto drains may become clogged.
- 3) Filters may accumulate moisture and/or contamination.

STEP 1)

Secure a primary air source of sufficient air flow and discharge pressure. The number and type of respirators being used determines the flow rate and pressure required.

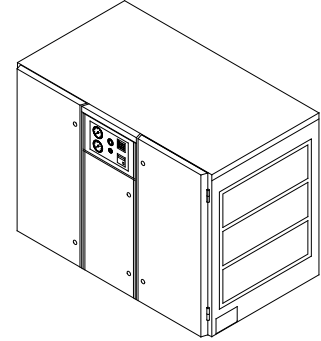

STEP 2)

Check airline monitor for fresh 9 volt batteries and turn unit on. Connect the remote signal cable, 115 VAC plug, and air sample hose to the monitor. Place the "ON/OFF/TEST" switch to the "ON" position. Allow 30 seconds for the readout to stabilize. If a reading other than "00" is displayed, calibration of the monitor may be necessary. See calibration procedure.

Note: Remote signal cable does not apply to BB15 series.

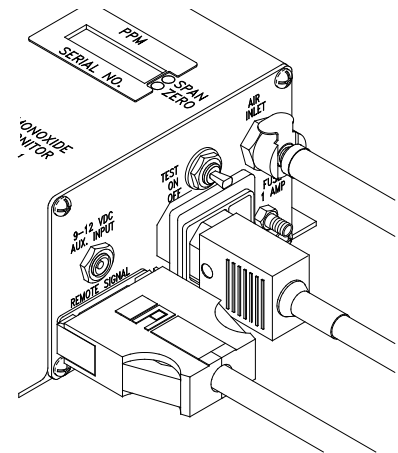

STEP 3)

Connect the extension cord to a 115 VAC receptacle.

Note: The CO monitor can run off the 9 volt batteries if AC power is not available.

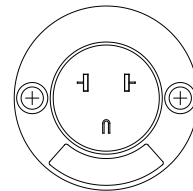

STEP 4)

Connect the optional remote alarm (DC only) assembly to the remote alarm jack.

Note: This step does not apply to BB15 series.

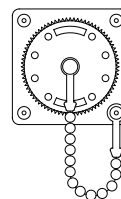

STEP 5)

Close the flowmeter by turning the control knob fully clockwise. Do not over-tighten.

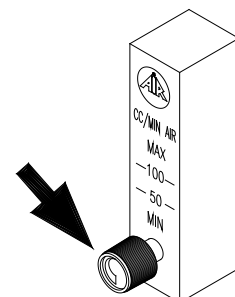

STEP 6)

Connect the air source, 150 psi max., to the inlet fitting.

MODEL #	MIN. HOSE I.D.	INLET FITTING
BB15 SERIES	3/8"	1/4" INDUSTRIAL INTERCHANGE
BB30-100 SERIES	1/2"	1/2" INDUSTRIAL INTERCHANGE
BB150 SERIES	3/4"	1" CHICAGO FITTING

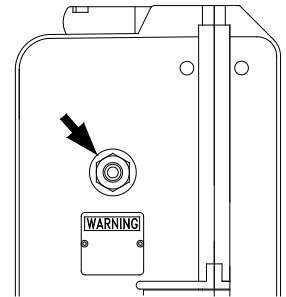

STEP 7)

Hold the "ON/OFF/TEST" switch in the "TEST" position. All local and remote audible/visual indicators will activate. If indicators do not activate, check all electrical connections, then call factory repair dept.

Note: An alarm function test can be performed at any time by lifting the "ON/OFF/TEST" switch to the "TEST" position.

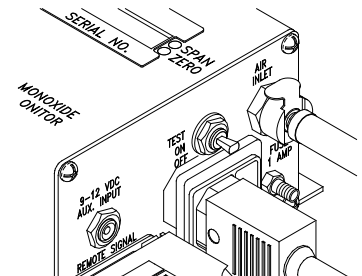

STEP 8)

Attach desired respirators and hoses to the quick connect couplings.

Note: Some models may not have respirator connections. They may be ordered with NPT outlets for connection to points of attachment.

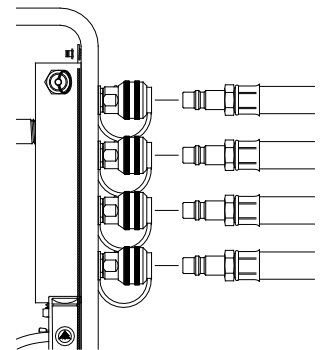

STEP 9)

Adjust the outlet pressure to the setting recommended by the respirator manufacturer. Turn the knob clockwise to increase pressure, counterclockwise to decrease pressure.

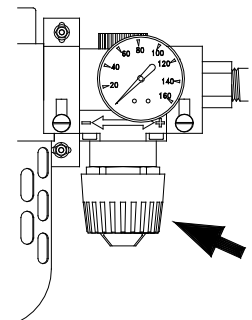

STEP 10)

Adjust CO monitor air sample flow rate by turning the flowmeter control knob counterclockwise until the ball hovers between 50 and 100 cc/min. The box is now ready for operation.

The monitor will analyze the air sample and display the CO concentration in parts per million (ppm). The system's green "NORMAL" operation light will illuminate, and the red "HIGH CO" light will flicker faintly approximately every second when the CO level is below 10ppm (5ppm Canadian).

When the CO concentration level exceeds the alarm set point, the green "NORMAL" light will turn off, the red "HIGH CO" light illuminates, the audible alarm will sound, and the remote alarm connections will energize.

When CO concentrations drop below the alarm set point, all alarm indicators will deactivate and return to normal operation.

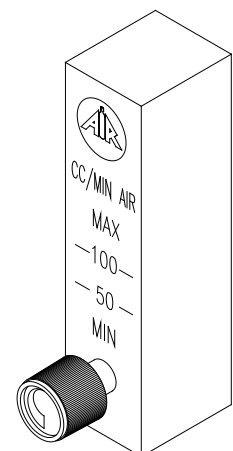

SHUTDOWN

- 1) Make sure all personnel have egressed from the work area.
- 2) Shut off air source to the box.
- 3) Remove air pressure from the box by pulling the relief valve ring out.
- 4) Turn the CO monitor off. Do not remove the 9 volt batteries. These are used to maintain a bias voltage to the sensor; this keeps the sensor ready for immediate use.
- 5) Disconnect airline hoses.
- 6) Install dust caps if applicable.

SYSTEM MAINTENANCE

CAUTION: Always depressurize the system before performing service.

Filter Housing/Bowls: Periodic cleaning of the polycarbonate bowls may become necessary. Remove the auto drains and clean the bowls with a mild soapy solution. The auto drains may also be cleaned with a mild soapy solution at this time. Dry and reinstall into the filter housing.

Filter Change: The filtration system consists of filter change indicators which will gradually change from green to orange when filter life is spent.

Note: Air must be flowing through the filters before the filter change indicators will function. With system pressurized, close inlet and outlet ball valves. Release the filter trio pressure by pressing the manual drain assembly to the side. Remove the bowl assemblies by releasing the lock ring.

Calibration: Monitor calibration should be done monthly or whenever the reading may be questionable. A calibration date sticker should be affixed for future reference. To obtain an accurate calibration, we recommend the use of Air Systems calibration kits.

Part Number:

BBK-10 Canadian calibration kit for CO monitor; 10ppm CO, zero air, regulator and case - 17 liter size.

BBK-20 Calibration kit for CO monitor; 20ppm CO, zero air, regulator and case - 17 liter size.

BBK-20103 Calibration kit for CO monitor; 20ppm CO, zero air, regulator and case - 103 liter size.

DECAL085 Calibration decal, sold in sheet of 14.

To assure sensor accuracy, calibration of monitor is required. If you cannot obtain an accurate calibration, sensor replacement may be necessary. Consult Repair Service Department before ordering.

Part Number:

CO-91NS Replacement CO sensor

MONITOR BATTERY REPLACEMENT

These batteries provide the required continuous bias voltage to the CO sensor and power the monitor in the event of AC power loss. If AC and DC power are removed for a period of 2 hours or more, a 1 hour restabilization period is required on the sensor as erratic readings may occur.

Battery Replacement: Replace 9 volt batteries when the amber "Low Battery" light illuminates. If the monitor is not used for 90 days, check the 9 volt batteries and replace if necessary.

SENSOR REPLACEMENT

Replacement sensors are shipped with a metal spring installed between the electrodes. Do not remove the clip until the sensor is to be installed into the monitor.

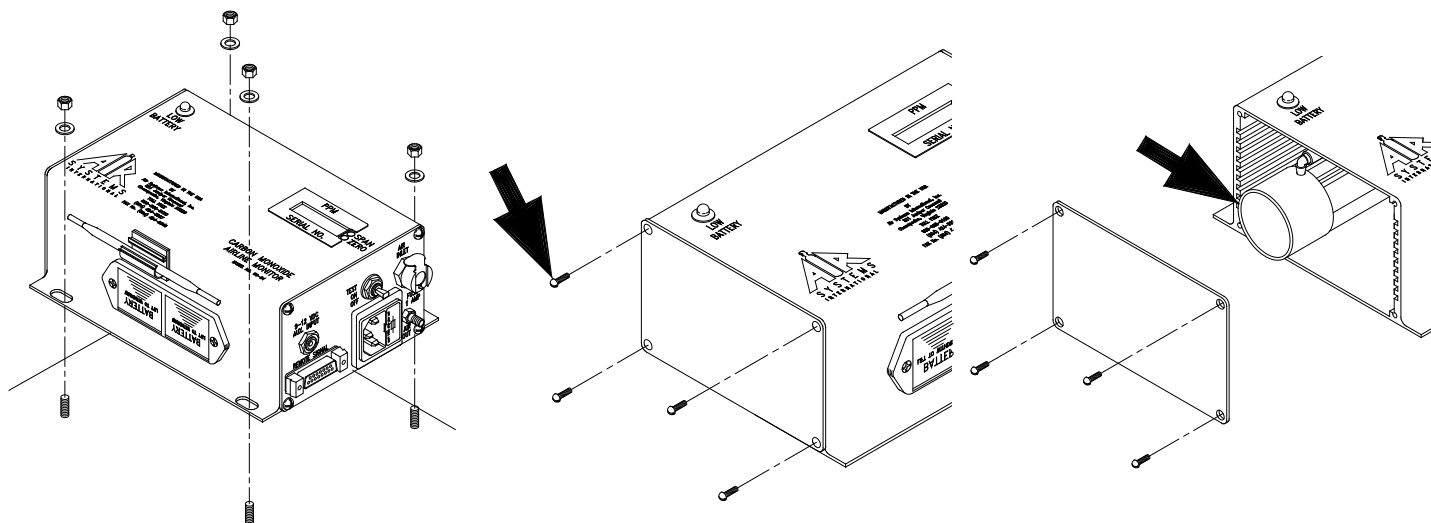

STEP 1)

Disconnect all external connections. Remove CO monitor from the unit.

STEP 2)

Remove the four screws from the monitor's left endplate.

STEP 3)

Remove endplate to gain access to the sensor cup.

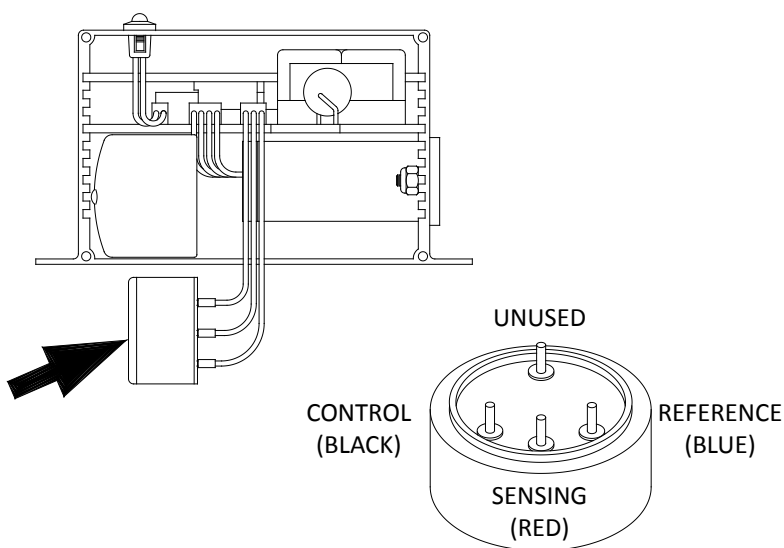

STEP 4)

Remove sensor from sensor cup and remove leads. Take the new sensor and remove the metal spring. Reattach leads to the proper colored terminals on the new sensor. Install new sensor into sensor cup.

STEP 5)

Reassemble monitor and reinstall in unit. Connect all cables and air sample hose. Allow monitor to stabilize 30 minutes to 1 hour and recalibrate.

CALIBRATION PROCEDURE

Do not use inert gases to zero the monitor. This will cause premature failure of the sensor.

CO Monitor Zero Adjustment

To zero the monitor, follow the steps below. Zero calibration gas should be used to properly “zero” the monitor and assure that a valid calibration is achieved. If zero adjustment cannot be made as indicated, sensor replacement may be necessary. **After each monitor adjustment outlined in the steps, allow time for the changes to stabilize.**

STEP 1)

Place the “ON/OFF/TEST” switch in the “ON” position.

STEP 2)

Allow 30 seconds for the readout to stabilize. The green indicator will illuminate.

STEP 3)

Hold the “ON/OFF/TEST” switch in the “TEST” position. The following will occur:

- Audible alarm will sound
- Green LED will flash
- Amber Low Battery indicator on monitor will illuminate
- Red LED will be on

This test ensures the circuitry is operable and continuity to the sensor is proper. Release the switch.

STEP 4)

Remove the air sample inlet tube.

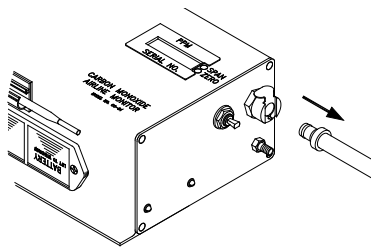

STEP 5)

Install regulator on the zero air cylinder reference gas.

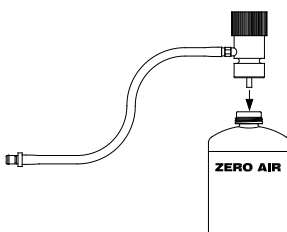

STEP 6)

Turn the knob on the regulator counterclockwise to allow the flow of gas thru the hose. Verify flow of gas thru the hose via touch or sound.

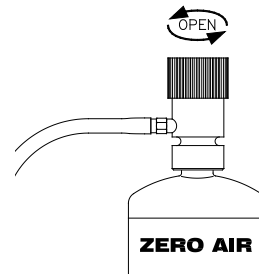

STEP 7)

Attach the clear tubing with the male plug to the air sample inlet on the monitor.

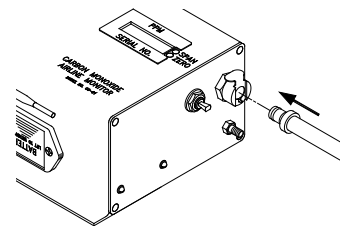

STEP 8)

Allow digital readout to stabilize approximately 15-30 seconds.

STEP 9)

Adjust the “zero” adjustment screw (clockwise to increase or counterclockwise to decrease) until a reading of “00” is obtained.

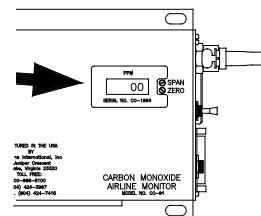

STEP 10)

Turn the regulator off and disconnect the regulator from the zero gas cylinder.

CALIBRATION PROCEDURE

CO Monitor Span Adjustment

Use only 10-20ppm CO gas for calibration. Using a higher concentration may decrease accuracy at lower scale readings. Note: 10ppm gas must be used to satisfy Canadian calibration requirements.

STEP 1)

Install regulator on the CO calibration gas cylinder.

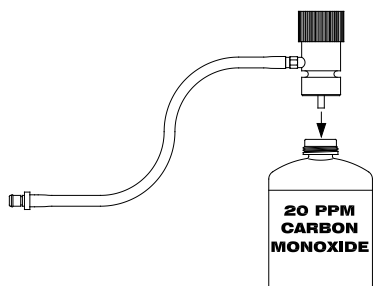

STEP 2)

Turn the knob on the regulator counterclockwise to allow the flow of gas thru the hose. Verify flow of gas thru the hose via touch or sound.

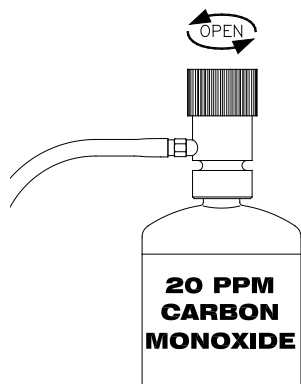

STEP 3)

Connect the plug to the air sample inlet on the monitor.

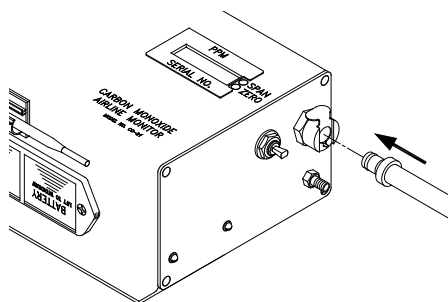

STEP 4)

Allow digital readout to stabilize 15-30 seconds.

STEP 5)

Adjust the "span" adjustment screw (clockwise to increase or counterclockwise to decrease) until the digital readout reads the same as the concentration (ppm) as printed on the calibration gas cylinder.

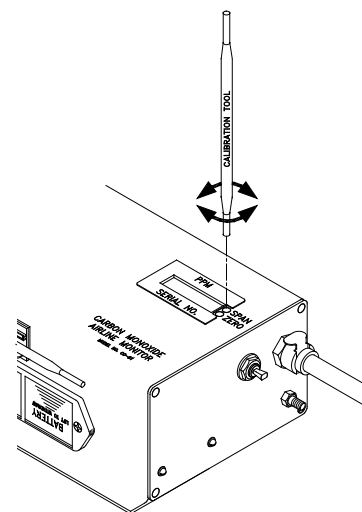

STEP 6)

Turn the regulator off and repeat the "zero" adjustment procedure. The digital readout should return to a "00" reading.

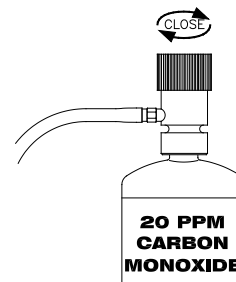

The monitor is now calibrated and should be recalibrated monthly or if accuracy is questionable. Check local requirements and recalibrate as required.

MODEL BB15-CO FILTER BREAKDOWN

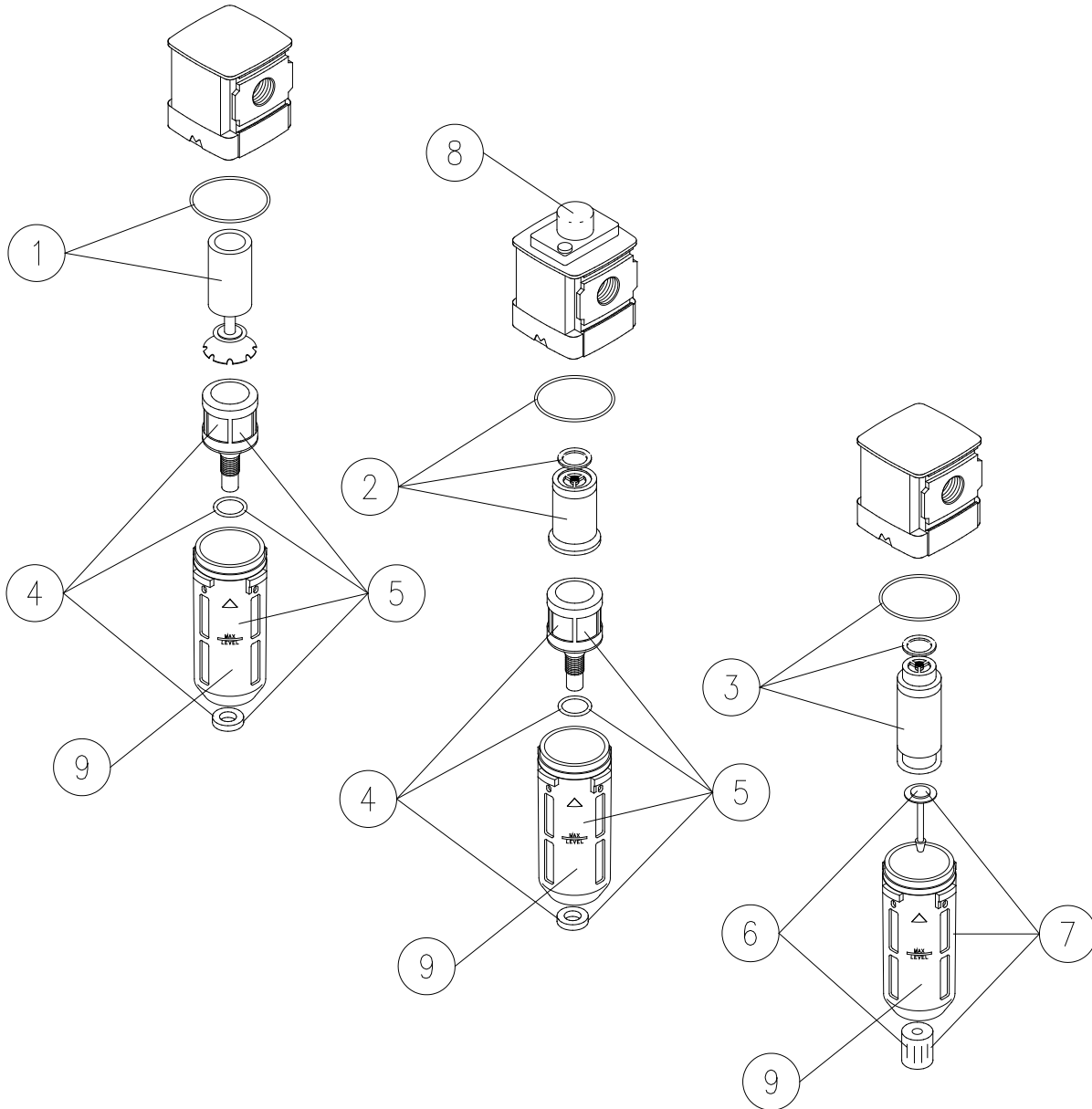

ITEM #	DESCRIPTION	PART #
1	"A" FILTER ELEMENT AND O-RING	BB15-AW
2	"C" FILTER ELEMENT AND O-RINGS	BB15-CW
3	"D" FILTER ELEMENT AND O-RINGS	BB15-DW
4	AUTO DRAIN ASSEMBLY	15ADW
5	FILTER BOWL WITH AUTO DRAIN ASSEMBLY	15-PBAW
6	MANUAL DRAIN	15MDW
7	FILTER BOWL WITH MANUAL DRAIN	15-PBMW
8	FILTER CHANGE INDICATOR	15DPW
9	FILTER BOWL GUARD	15PBGW

NOTE: For BB15 series units purchased prior to 12/04, please contact customer service for correct ordering information on replacement filter components.

MODEL BB30-CO FILTER BREAKDOWN

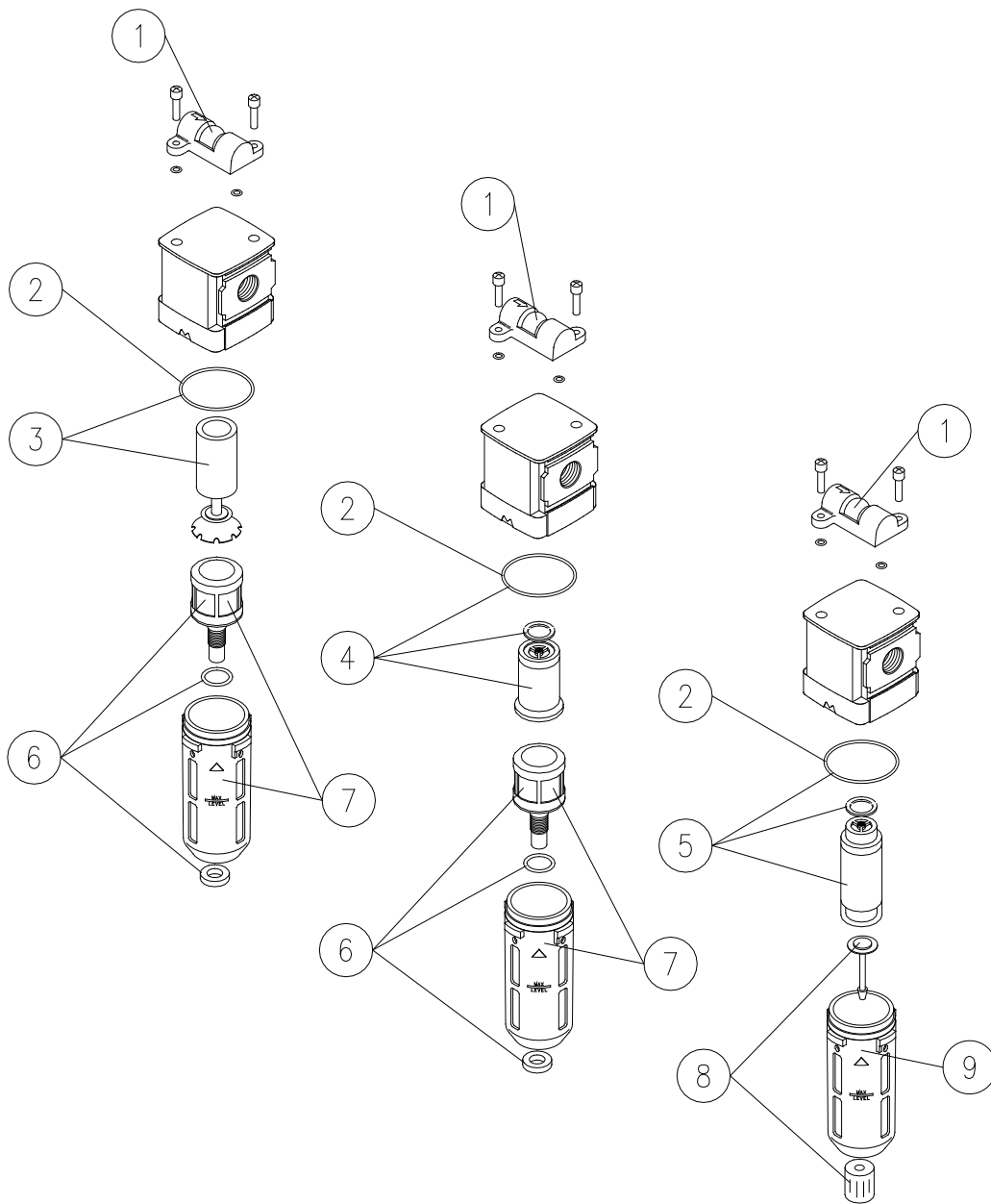

ITEM #	DESCRIPTION	PART #
1	FILTER CHANGE INDICATOR	WL261
2	FILTER BOWL O-RING	WL266
3	"A" FILTER ELEMENT AND O-RING	BB30-A
4	"C" FILTER ELEMENT AND O-RINGS	BB30-C
5	"D" FILTER ELEMENT AND O-RINGS	BB30-D
6	AUTO DRAIN ASSEMBLY	WL024
7	FILTER BOWL WITH GUARD AND AUTO DRAIN	WL264
8	MANUAL DRAIN	WL262
9	FILTER BOWL WITH GUARD (NO DRAIN)	WL267

MODEL BB50-CO FILTER BREAKDOWN

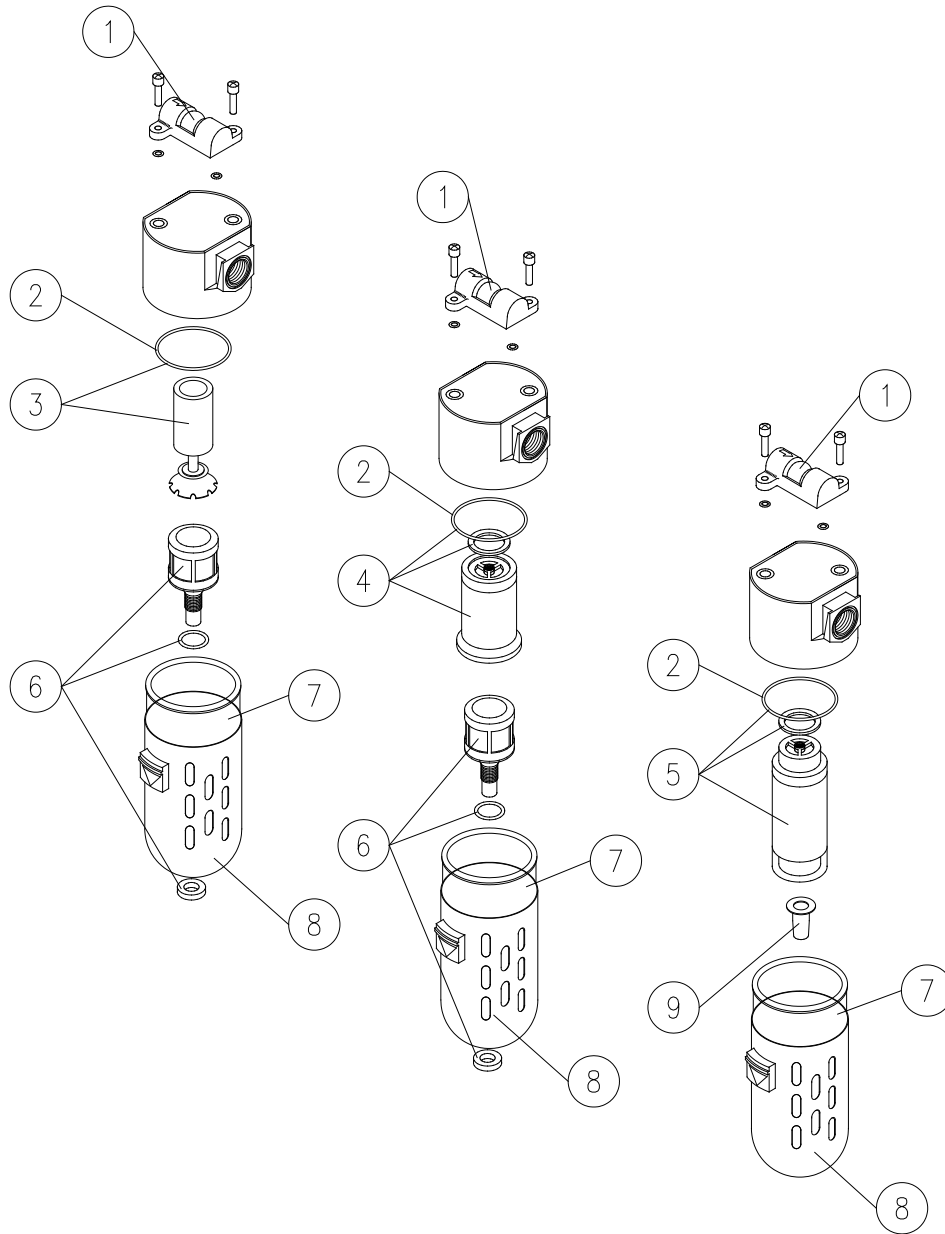

ITEM #	DESCRIPTION	PART #
1	FILTER CHANGE INDICATOR	WL056
2	FILTER BOWL O-RING	WL091
3	"A" FILTER ELEMENT AND O-RING	BB50-A
4	"C" FILTER ELEMENT AND O-RINGS	BB50-C
5	"D" FILTER ELEMENT AND O-RINGS	BB50-D
6	AUTO DRAIN ASSEMBLY	WL024
7	PLASTIC FILTER BOWL	WL049
8	METAL FILTER BOWL GUARD	WL094
9	MANUAL DRAIN	WL153

MODEL BB75-CO FILTER BREAKDOWN

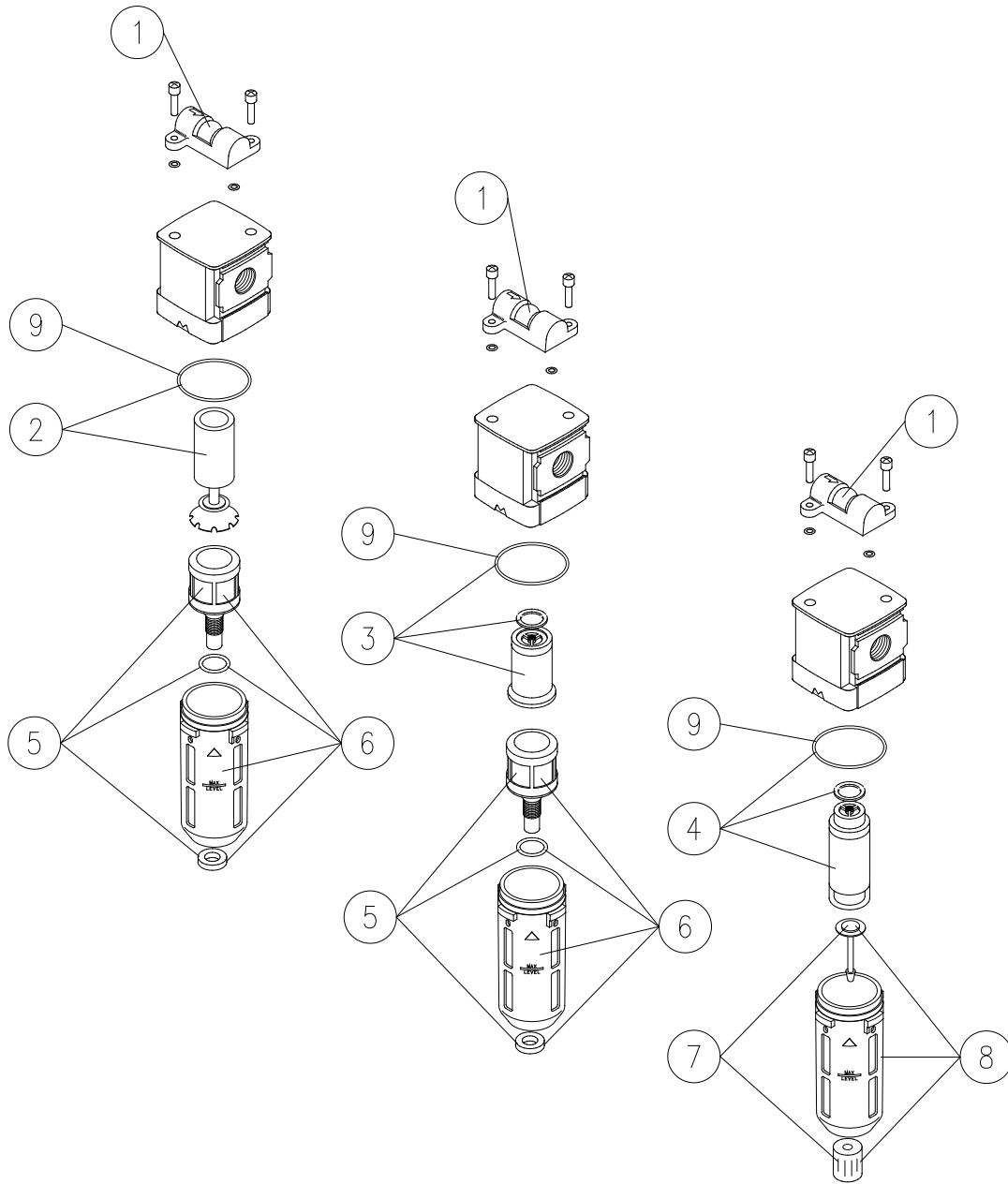

ITEM #	DESCRIPTION	PART #
1	FILTER CHANGE INDICATOR	WL261
2	"A" FILTER ELEMENT AND O-RING	BB75-A
3	"C" FILTER ELEMENT AND O-RINGS	BB75-C
4	"D" FILTER ELEMENT AND O-RINGS	BB75-D
5	AUTO DRAIN ASSEMBLY	WL024
6	FILTER BOWL WITH AUTO DRAIN	WL187
7	MANUAL DRAIN	WL262
8	FILTER BOWL WITH MANUAL DRAIN	WL188
9	FILTER BOWL O-RING	WL189

MODEL BB100-CO/BB150-CO FILTER BREAKDOWN

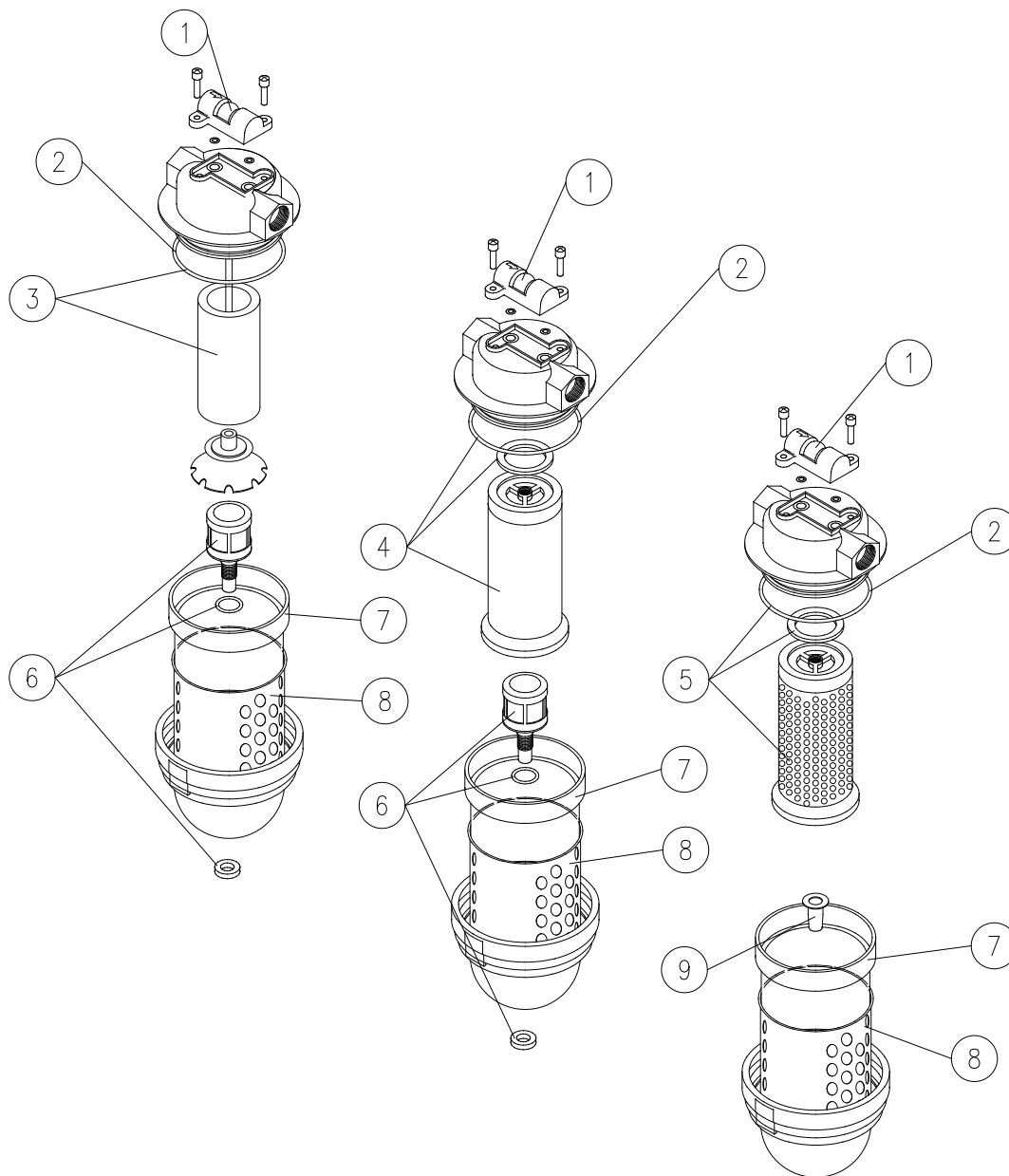

ITEM #	DESCRIPTION	PART #
1	FILTER CHANGE INDICATOR*	WL056
2	FILTER BOWL O-RING	WL113
3	"A" FILTER ELEMENT AND O-RING	BB100-A
4	"C" FILTER ELEMENT AND O-RINGS	BB100-C
5	"D" FILTER ELEMENT AND O-RINGS	BB100-D
6	AUTO DRAIN ASSEMBLY	WL024
7	PLASTIC FILTER BOWL	WL055
8	METAL FILTER BOWL GUARD	WL092
9	MANUAL DRAIN	WL153

NOTE: On MODEL BB100-CO filters (shown above) filter change indicators are on all three filters. On MODEL BB150-CO only the "C" filter has a filter change indicator.

WARRANTY DISCLAIMER

Air Systems' manufactured equipment is warranted to the original user against defects in workmanship or materials under normal use for one year from the date of purchase. Any part which is determined by Air Systems to be defective in material or workmanship will be, as the exclusive remedy, repaired or replaced at Air Systems' option. This warranty does not apply to electrical systems or electronic components. Electrical parts are warranted, to the original user, for 90 days from the date of sale. During the warranty period, electrical components will be repaired or replaced at Air Systems' option.

NO OTHER WARRANTY, EXPRESSED OR IMPLIED, AS TO DESCRIPTION, QUALITY, MERCHANTABILITY, FITNESS FOR A PARTICULAR PURPOSE, OR ANY OTHER MATTER IS GIVEN BY AIR SYSTEMS IN CONNECTION HEREWITH. UNDER NO CIRCUMSTANCES SHALL THE SELLER BE LIABLE FOR LOSS OF PROFITS, ANY OTHER DIRECT OR INDIRECT COSTS, EXPENSES, LOSSES, OR DAMAGES ARISING OUT OF DEFECTS IN, OR FAILURE OF THE PRODUCT OR ANY PART THEREOF.

The purchaser shall be solely responsible for compliance with all applicable Federal, State and Local OSHA and/or MSHA requirements. Although Air Systems International believes that its products, if operated and maintained as shipped from the factory and in accordance with our "operations manual", conform to OSHA and/or MSHA requirements, there are no implied or expressed warranties of such compliance extending beyond the limited warranty described herein. Product designs and specifications are subject to change without notice. **Rev. 2, 12/98**

Air leaks are not covered under warranty except when they result from a defective system component, i.e. an on/off valve or regulator or upon initial delivery due to poor workmanship. Air leaks due to poor delivery or damage will be covered under delivery claims. Minor air leaks are part of routine service and maintenance and are the responsibility of the customer just as are filters and oil changes.



AIR SYSTEMS INTERNATIONAL, INC.

829 Juniper Crescent, Chesapeake, Va 23320

Telephone (757) 424-3967

Toll Free 1-800-866-8100

Fax No. (757) 424-5348

<http://www.airsystems.com>

e-mail: sales@airsystems.com

**SYSTEMS
INTERNATIONAL**

